

PERFECTION GEAR
PERFECTION GEAR
PERFECTION GEAR
PERFECTION GEAR
PERFECTION GEAR
PERFECTION GEAR
PERFECTION GEAR
PERFECTION GEAR
PERFECTION GEAR
PERFECTION GEAR
PERFECTION GEAR
PERFECTION GEAR

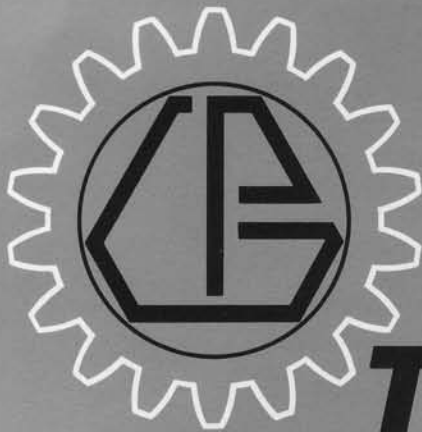

PERFECTION GEAR
MOTORS
and GEARING

POWER TRANSMISSION PRODUCTS

Introduction	2
Worm Gear Speed Reducers	2
Modular Worm Gear Speed Reducers	3
Selection Guide	4-6
Engineering Data	7-9
Quick Selection Charts	10-11
Ratings Charts	12-15
How To Order Worm Gear Reducers	16
Dimensions with Drawings	17-58
How To Order Modular Worm Gear Reducers	44
Modular Box Base Options	59
Accessories	
Torque Arm	60
Jaw Couplings and Motor Adapters	61
Input and Output Bushings	62
Spiral Bevel Gear Box	63-66
Mounting Assemblies	67
Vent Plug Locations	68
Oil Capacities	68
Shipping Weights	68
Service	69

USES AND ADVANTAGES

Of all methods of mechanical speed changing, worm gearing provides the largest reductions in the smallest space, and at the same time, offers maximum increases in torque capacity.

Perfection Gear reducers keep downtime to a minimum: they have a minimum number of moving parts; are tightly enclosed to keep lubrication in, dust and foreign matter out; and are built to withstand high shock loads and high momentary overloads.

Yet, for all their capacity for workload, worm gear speed reducers run smoothly and are surprisingly quiet in operation. However, the feature that contributes most to keeping the worm gear in steady operation is that **its design resists wear**: initial wear does not destroy the tooth form. Instead, the worm continues to generate the gear tooth as the original cutting of the gear. In effect, the worm gears **wear in**—other types **wear out**.

PRECISION ENGINEERED AND PERFORMANCE TESTED

Perfection Gear reducers are **precision** units throughout. A precision worm is mated with a precision worm gear, both are precisely and rigidly mounted on antifriction bearings, then contained in a tight cast iron housing that allows continuous lubrication and adequate heat dissipation. Clean, simple, and precise.

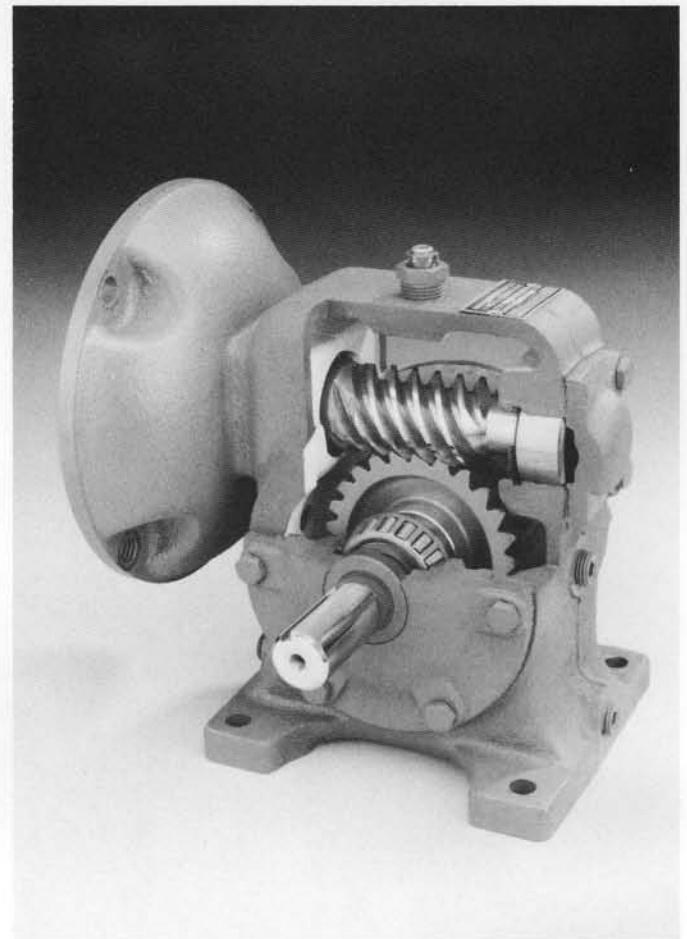

WORM GEAR COMPONENTS

There are seven main components that make up the worm gear reducer—worm gear, worm, shaft, housing, caps, bearings, and seals.

THE WORM GEAR: Perfection Gear is a leader in the development of a special forged C60300 bronze worm gear material. Because these forgings have a dense grain structure, they have a high tensile strength. This dense, consistent grain structure also means long life, uniform wear, and lack of hard or soft spots, porosity and cracks.

THE WORM: Perfection Gear reducers are made from 8620 alloy steel and are integral with the input shaft. This one-piece construction increases strength, accuracy and efficiency. Threads are milled or rolled, then case hardened, and ground to close tolerances. The shaft is ground and the oil seal area is polished. They are case hardened to 57-62 RC for wearability, retaining a tough ductile core for maximum strength.

The C, L and G motor codes use a quill type worm for maximum space conservation and strength when using a N.E.M.A. C-face motor.

MODULAR WORM GEAR SPEED REDUCERS

The M and MA styles can be installed in the field and use a flexible coupling to allow for misalignment between the motor shaft and the worm shaft when using a N.E.M.A. C-face motor.

THE OUTPUT SHAFT: All are made from stress-proof¹ steel, which is a treated, stress-relieved medium-carbon steel. The structure of this material permits it to carry full torsional and overhung load. The entire shaft is ground and the area in contact with the oil seal is polished.

Larger shaft diameters are available on most styles in the 1300-3800 series units providing greater overhung load ratings.

HOUSINGS: All housings in the standard line are one-piece castings, made from close grained, gray iron. The use of cast iron gives the rigidity, strength and dimensional stability that the gearing and bearings need for long dependable service. Precision CNC machining in one setup insures the accuracy needed for proper mounting of the worm and gear.

CAPS: All caps are bolt on caps made of iron base material. This allows for fine adjustment of the gearing, bearing preload by the use of shims and ease of maintenance. This also adds to the dimensional stability of the reducer.

BEARINGS: All bearings on output shafts, and on input shafts on non-quilled units, are tapered roller bearings. Input shafts on quilled units use an angular contact double-row ball bearing.

SEALS: Every unit is tested thoroughly to insure that all oil seals function properly by applying air pressure to the reducer while submerged in a water tank. This method allows the detection of even the smallest leaks and is used 100% on all Perfection reducers. Seal material on standard units are nitrile, good for temperatures from -65° to 225° F. Other seal materials are available to meet extreme conditions.

¹ Stressproof is a registered trademark of the LaSalle Steel Co.

MODULAR WORM GEAR FEATURES AND OPTIONS

- Housings machined for bases to be bolted on top or bottom.
- Bases are available to adapt to your present equipment design.
- Universal housings can be used for floor, wall or ceiling mount.
- Bases are made from cast iron or steel for uniform expansion and support of cast iron housings.
- Caps both input and output are bolt on for precise alignment of gears, preload of bearings, and easy service access.
- Hollow output shaft style allows for shaft mounting of the reducer.
- Alternate output shaft option allows you to specify larger output shaft diameters and extended lengths.
- Bearings used on optional output shaft allow for greater load carrying capacity.

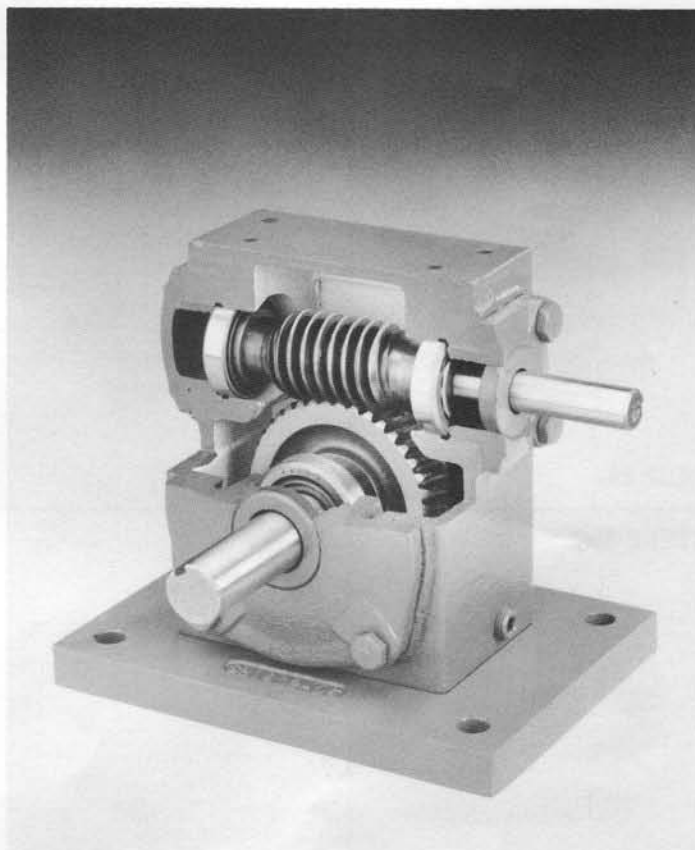

SELECTION GUIDE

<p>STYLE SB</p>  <p>PAGE 17</p>	<p>STYLE ST</p>  <p>PAGE 18</p>	<p>STYLE V</p>  <p>PAGE 19</p>	<p>STYLE RA</p>  <p>PAGE 20</p>
<p>STYLE N</p>  <p>PAGE 21</p>	<p>STYLE T*</p>  <p>PAGE 22</p>	<p>STYLE V*</p>  <p>PAGE 23</p>	<p>STYLE RA*</p>  <p>PAGE 24</p>
<p>STYLE N*</p>  <p>PAGE 25</p>	<p>STYLE MT*</p>  <p>PAGE 26</p>	<p>STYLE MV*</p>  <p>PAGE 27</p>	<p>STYLE MRA*</p>  <p>PAGE 28</p>
<p>STYLE MN*</p>  <p>PAGE 29</p>	<p>STYLE SD</p>  <p>PAGE 30</p>	<p>STYLE SCD</p>  <p>PAGE 31</p>	<p>STYLE RH SPIRAL BEVEL GEAR BOX</p>  <p>PAGE 66</p>

*Motor Code

STYLE TD

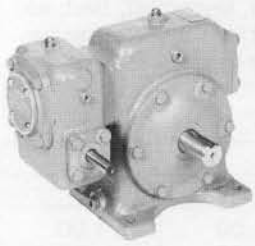

PAGE 32

STYLE VD



PAGE 33

STYLE RD



PAGE 34

STYLE ND



PAGE 35

STYLE T* D

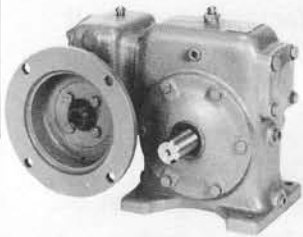

PAGE 36

STYLE V* D



PAGE 37

STYLE R* D

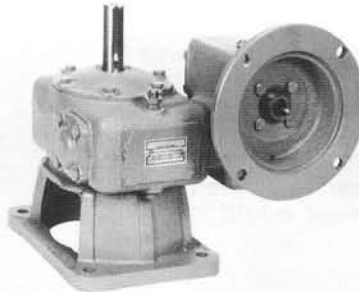

PAGE 38

STYLE N* D

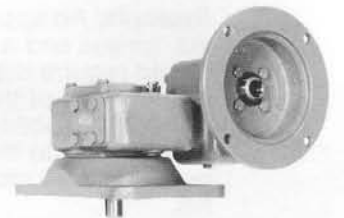

PAGE 39

STYLE MT*D

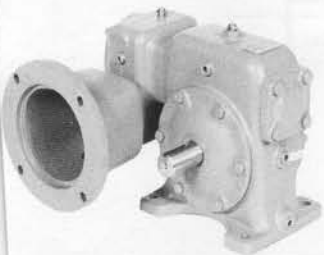

PAGE 40

STYLE MV*D



PAGE 41

STYLE MR*D

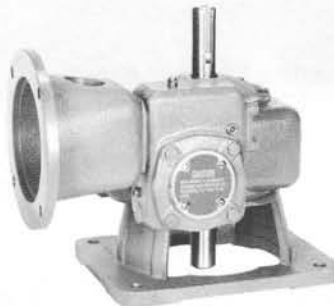

PAGE 42

STYLE MN*D

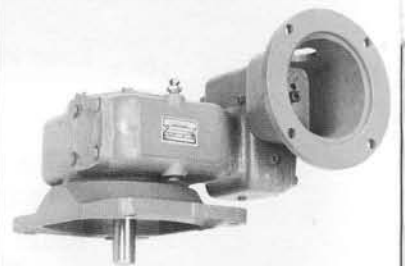

PAGE 43

STYLE H



PAGE 45

STYLE HH

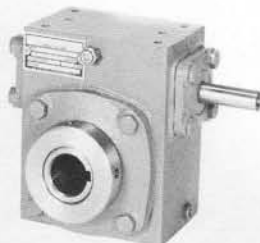

PAGE 46

STYLE KH

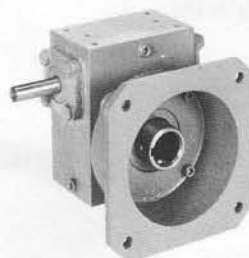

PAGE 47

STYLE H*



PAGE 48

STYLE H* H



PAGE 49

STYLE K* H

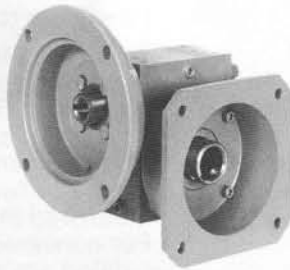

PAGE 50

STYLE K*



PAGE 51

STYLE HD

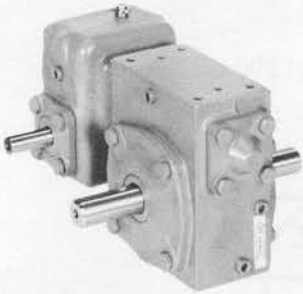

PAGE 52

STYLE HDD



PAGE 53

STYLE KHD

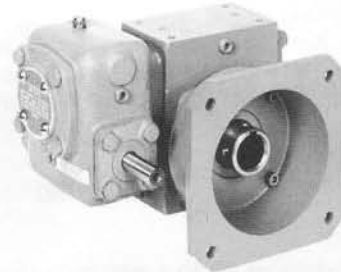

PAGE 54

STYLE H* D



PAGE 55

STYLE H* HD



PAGE 56

STYLE K* HD

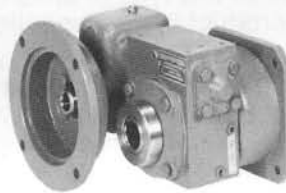

PAGE 57

STYLE K* D

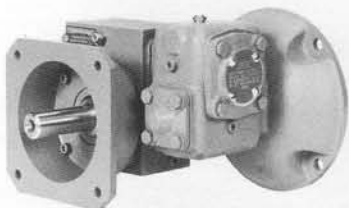

PAGE 58

**MODULAR BOX
BASE OPTIONS**

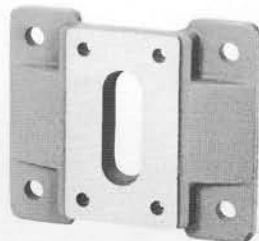

PAGE 59

M FLANGE KIT



PAGE 61



PERFECTION GEAR

WORM GEAR REDUCER ENGINEERING DATA

Information you need to help choose your Perfection Worm Gear Reducer.

The proper selection of a worm gear reducer depends on a complete knowledge of the job to be done and the type and amount of power needed to do the job.

To make the proper selection you must know the following:

- Page 7 1. Ratio
- 2. Torque
- Page 8 3. Horsepower
- 4. Overhung Load
- Page 9 5. Service Factors

1. RATIO

Ratio (R) is the relationship of the high speed (input) RPM to the slow speed (output).

Example: An example is an electric motor at approximately 1800 RPM that is used to drive a machine which requires approximately 30 RPM.

$$R = \frac{1800 \text{ RPM}}{30 \text{ RPM}} \text{ or } R = 60$$

The total ratio of 60 to 1 can be a direct drive using a speed reducer that has a 60 to 1 ratio.

This same action can be accomplished by using a smaller reduction in the reducer, and a secondary reduction from the output shaft of the reducer to the machine that is being driven. In this type of drive the total ratio is the product of the two ratios.

Example: Just as an 1800 RPM motor and a 60 to 1 reducer gives a final speed of 30 RPM, a 20 to 1 reducer and a 3 to 1 gear or chain drive from the output shaft gives a final speed of 30 RPM.

2. TORQUE

Torque is the twisting force or power needed to run an item rotationally.

Torque is the effort needed to unscrew the cap from a jar or to crank a handle to raise an awning. This effort can be measured by applying a known load at a known distance from the center of the item that is to be turned or twisted. This effort can be measured in pound inches or pound feet: For convenience, all specifications in this catalog are shown in pound inches.

Example: If a crank arm is 10" long and rotation will start after 20 pounds of weight is exerted, then the torque is 200 LB INCHES.

$$T = \text{Load} \times \text{Radius}$$

$$T = 20 \text{ lbs.} \times 10'' = T \text{ of } 200 \text{ LB INCHES}$$

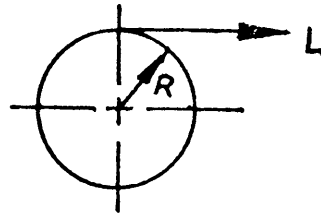

It is important to remember that the torque required to start rotation is always greater than the torque required to keep it in motion. Therefore, torque requirements must be measured at maximum or starting loads.

Torque is not changed by time or speed. A 10" crank that requires 20 lbs. of effort will require 200" lbs. of torque regardless of the speed with which the crank is turned.

There are two reasons for compounding an auxiliary drive from the output shaft of the reducer. First, it offers the opportunity to obtain the exact speed required at the machine using standard ratio reducers. Second, the smaller ratio can transmit higher horsepower. Because the torque compounds in the same manner as the auxiliary reduction ratio, it is possible to use a smaller reducer to do the job.

Example: An application which requires 1500" lbs. torque and a 60 to 1 ratio as a direct drive would require the full 1500" lbs. of torque at the output shaft of the reducer. If an auxiliary drive of 3 to 1 reduction were used from the reducer output shaft to the driven machine the reducer output torque requirement would be only 500" lbs.

3. HORSEPOWER

Horsepower is the measure of work effort in a given amount of time.

The established definition of horsepower is the amount of power required to lift 33,000 pounds one foot in one minute.

$$HP = \frac{\text{Load in pounds} \times \text{Feet per minute}}{33,000}$$

Since torque (T) equals load x radius

$$HP = \frac{T \times RPM}{63025} \quad \text{or} \quad T = \frac{HP \times 63025}{RPM}$$

Example: The torque required on the 10" crank remains the same, 200" lbs., whether at 100 RPM, 500 RPM, or 1000 RPM . . . but the horsepower required to do the work at these speeds will vary. Using the above formula, the horsepower required at 100 RPM is .318, at 500 RPM it is 1.59, and at 1000 RPM it is 3.18.

4. OVERHUNG LOAD

Overhung Load (OHL) is the "bending" load imposed on a shaft by a gear, sprocket, belt, etc. If this load is great enough it will put excessive strain on the shaft and cause fatigue failure.

OVERHUNG LOAD FACTORS

TRANSMISSION METHOD	FACTORS	
	A	B
Sprockets	1.00	1.00
Gears	1.25	.80
V-Belts	1.50	.67
Flat Belts	2.50	.40

Factors in column "A" are to be applied to required torque as calculated in Step 3. Factors in Column "B" are to be applied to catalog rated torque.

Important: Use only one OHL factor correction. If you use column "A" to compensate your calculated Overhung Load DO NOT use column "B".

To determine OHL:

$$\text{Overhung Load (OHL)} = \frac{\text{Torque}}{\text{Radius of gear, sprocket, etc.}}$$

OHL ratings in this catalog are for one shaft diameter from face of cap.

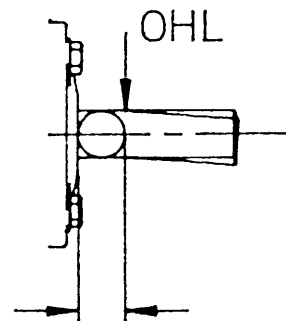

ONE SHAFT DIAMETER

5. SERVICE FACTORS

Proper use of the service factor will assure a dependable smooth running drive. A 1.00 service factor is used when the application is free from recurrent shock loading and is continuous but does not exceed 10 hours per day. Using the service factor table, select the proper overload service factor for your application and apply this formula:

$$\frac{\text{HP from Catalog Chart}}{\text{Service Factor}} = \text{Application HP}$$

The catalog ratings may be used without adjustment if the actual driven machine, horsepower and torque requirements are multiplied by the appropriate service factor indicated in the table below.

SERVICE FACTORS

PRIME MOVER	DURATION OF SERVICE TOTAL OPERATING TIME PER DAY	DRIVEN MACHINE LOAD CLASSIFICATIONS		
		UNIFORM	MODERATE SHOCK	HEAVY SHOCK
Electric Motor	Occasional ½ Hour	0.80	0.90	1.00
	Intermittent 2 Hours	0.90	1.00	1.25
	10 Hours	1.00	1.25	1.50
	24 Hours	1.25	1.50	1.75
Multi-Cylinder Internal Combustion Engine	Occasional ½ Hour	0.90	1.00	1.25
	Intermittent 2 Hours	1.00	1.25	1.50
	10 Hours	1.25	1.50	1.75
	24 Hours	1.50	1.75	2.00
Single Cylinder Internal Combustion Engine	Occasional ½ Hour	1.00	1.25	1.50
	Intermittent 2 Hours	1.25	1.50	1.75
	10 Hours	1.50	1.75	2.00
	24 Hours	1.75	2.00	2.25

SERVICE FACTORS FOR FREQUENT STARTS AND STOPS*

Electric Motor	Occasional ½ Hour	0.90	1.00	1.25
	Intermittent 2 Hours	1.00	1.25	1.50
	10 Hours	1.25	1.50	1.75
	24 Hours	1.50	1.75	2.00

*Frequent starts and stops refers to more than 10 starts per hour.

QUICK SELECTION CHART

SINGLE REDUCTION (1.0 SERVICE FACTOR)

RATIO	OUTPUT RPM	INPUT HORSEPOWER AT 1750 R.P.M.												
		1/6	1/4	1/3	1/2	3/4	1	1 1/2	2	3	5	7 1/2	10	15
4	438	1300	1300	1300	1300	1300	1300	1300	1800					
5	350	1300	1300	1300	1300	1300	1300	1800	1800	2100	2400			
10	175	1300	1300	1300	1300	1300	1800	1800	2100	2400	3200	3800	4500	5200
15	117	1300	1300	1300	1300	1800	1800	2100	2400	2600	3200	4500	4500	
20	88	1300	1300	1300	1300	1800	1800	2100	2400	3200	3800	4500	5200	
25	70	1300	1300	1300	1300	1800	2100	2400	2600	3200	4500	5200		
30	58	1300	1300	1300	1800	1800	2100	2400	3200	3800	4500	5200		
40	44	1300	1300	1300	1800	2100	2400	2600	3200	3800	5200			
50	35	1300	1300	1800	1800	2100	2600	3200	3800	4500	5200			
60	29	1300	1300	1800	2100	2400	2600	3200	3800	5200				

For Actual Ratings See Pages 12-13

AVAILABLE MOTOR ADAPTERS

MOTOR FLANGE CODE	MOTOR FRAME	FLANGE REGISTER	INPUT BORE
C	56C	4.50"	.625
L	143TC, 145TC, 182C, 184C	4.50"	.875
G	182TC, 184TC	8.50"	1.125
W	213TC, 215TC	8.50"	1.375
Y	HYDRAULIC MOTOR	3.25"	1.000

AVAILABLE MOTOR ADAPTERS BY RATIO

RATIO	REDUCER SIZE								
	1300	1800	2100	2400	2600	3200	3800	4500	5200
4	C	C	---	---	---	---	---	---	---
5	C	C	C, L	C, L,*	C, L,*	---	---	---	---
10	C	C	C, L	C, L,*	C, L,*	C, L, G	G	G, W	G, W
15	C	C	C, L	C, L	C, L,*	C, L, G	L, G	G, W	L, G, W
20	C	C	C, L	C, L	C, L	C, L, G	C, L, G	L, G, W	G, W
25	C	C	C	C, L	C, L	C, L, G, Y	C, L, G	L, G	G, W
30	C	C	C	C, L	C, L	C, L, G	C, L, G	L, G	L, G, W
40	C	C	C	C, L	C, L	C, L, G	C, L, G	C, L, G	L, G
50	C	C	C	C, L	C, L	C, L	C, L, G	C, L, G	L, G
60	C	C	C	C	C, L	C, L	C, L, G, Y	C, L, G	L, G

**"G" Motor Flange Available in "M" Style Only.

QUICK SELECTION CHART

DOUBLE REDUCTION (1.0 SERVICE FACTOR)

RATIO	OUTPUT RPM	INPUT HORSEPOWER AT 1750 R.P.M.									
		1/6	1/4	1/3	1/2	3/4	1	1 1/2	2	3	5
16	109.4	130000	130000	130000	130000	---	---	---	---	---	---
20	87.5	130000	130000	130000	130000	---	---	---	---	---	---
25	70.0	130000	130000	130000	---	---	---	---	---	---	---
40	43.8	130000	130000	130000	---	---	---	---	---	---	---
50	35.0	130000	130000	---	---	---	---	---	---	---	---
60	29.2	130000	130000	---	---	---	---	---	---	---	---
75	23.3	130000	130000	180000	180000	210000	260000	320000	320000	450000	520000
80	21.9	130000	180000	180000	180000	240000	260000	---	---	---	---
100	17.5	130000	180000	180000	210000	240000	260000	320000	380000	450000	520000
120	14.6	130000	180000	180000	210000	240000	---	---	---	---	---
125	14.0	130000	180000	210000	210000	260000	320000	320000	450000	520000	---
150	11.7	180000	180000	210000	240000	260000	320000	380000	450000	520000	---
160	10.9	180000	180000	180000	240000	260000	---	---	---	---	---
200	8.8	180000	180000	210000	260000	320000	320000	450000	450000	520000	---
225	7.8	180000	210000	210000	260000	320000	380000	450000	520000	520000	---
240	7.3	180000	210000	210000	260000	---	---	---	---	---	---
250	7.0	180000	210000	240000	320000	320000	380000	450000	520000	---	---
300	5.8	180000	210000	240000	320000	320000	380000	520000	520000	---	---
375	4.7	210000	240000	260000	320000	380000	450000	520000	520000	---	---
400	4.4	210000	240000	260000	320000	380000	450000	520000	520000	---	---
450	3.9	210000	240000	260000	320000	380000	450000	520000	---	---	---
500	3.5	210000	240000	320000	320000	450000	450000	520000	---	---	---
600	2.9	240000	260000	320000	320000	450000	450000	520000	---	---	---
750	2.3	240000	260000	320000	450000	450000	520000	---	---	---	---
800	2.02	240000	260000	320000	380000	450000	520000	---	---	---	---
900	1.90	240000	320000	320000	380000	520000	520000	---	---	---	---
1000	1.75	240000	320000	320000	450000	520000	520000	---	---	---	---
1200	1.46	260000	320000	320000	450000	520000	520000	---	---	---	---
1250	1.40	260000	320000	380000	450000	520000	---	---	---	---	---
1500	1.17	260000	320000	380000	450000	520000	---	---	---	---	---
1600	1.99	260000	320000	380000	450000	520000	---	---	---	---	---
1800	.97	320000	320000	380000	450000	---	---	---	---	---	---
2000	.88	320000	380000	450000	520000	---	---	---	---	---	---
2400	.73	320000	380000	450000	520000	---	---	---	---	---	---
2500	.70	380000	380000	520000	520000	---	---	---	---	---	---
3000	.58	380000	450000	520000	520000	---	---	---	---	---	---
3600	.49	380000	450000	520000	---	---	---	---	---	---	---

For Actual Ratings See Pages 14-15

SINGLE REDUCTION WORM GEAR REDUCER RATING TABLE

			SIZE 1300 O.P. OHL = 219 LBS.						SIZE 1800 O.P. OHL = 378 LBS.						SIZE 2100 O.P. OHL = 525 LBS.		
			MECHANICAL			THERMAL			MECHANICAL			THERMAL			MECHANICAL		
RATIO	I.P. RPM	O.P. RPM	I.P. HP	O.P. HP	O.P. TRQ	I.P. HP	O.P. HP	O.P. TRQ	I.P. HP	O.P. HP	O.P. TRQ	I.P. HP	O.P. HP	O.P. TRQ	I.P. HP	O.P. HP	O.P. TRQ
4	1750	438	1.57	1.45	209	0.85	0.79	144	2.95	2.75	397	1.62	1.51	217	—	—	—
	1150	288	1.27	1.15	252	0.68	0.62	136	2.44	2.25	493	1.28	1.18	258	—	—	—
	850	213	1.04	0.93	276	0.56	0.51	150	2.05	1.86	553	1.25	1.15	342	—	—	—
	690	173	0.89	0.79	289	—	—	—	1.78	1.61	588	—	—	—	—	—	—
	100	25	0.16	0.14	343	—	—	—	0.34	0.29	726	—	—	—	—	—	—
5	1750	350	1.46	1.34	242	0.95	0.88	158	2.72	2.53	455	1.49	1.37	246	3.89	3.63	654
	1150	230	1.14	1.03	283	0.74	0.68	185	2.21	2.02	553	1.28	1.17	320	3.24	2.98	816
	850	170	0.92	0.82	305	0.57	0.51	189	1.82	1.65	611	1.25	1.14	423	2.72	2.48	919
	690	138	0.79	0.70	318	—	—	—	1.57	1.41	643	—	—	—	2.38	2.14	979
	100	20	0.14	0.12	366	—	—	—	0.29	0.24	771	—	—	—	0.46	0.39	1214
10	1750	175	0.95	0.82	295	0.61	0.53	192	1.77	1.55	559	0.88	0.79	285	2.56	2.27	819
	1150	115	0.74	0.62	341	0.48	0.41	222	1.42	1.22	671	0.84	0.73	399	2.10	1.83	1001
	850	85	0.60	0.49	365	0.39	0.32	238	1.18	0.99	736	0.77	0.65	482	1.75	1.50	1111
	690	69	0.51	0.41	379	—	—	—	1.02	0.84	770	—	—	—	1.52	1.28	1171
	100	10	0.09	0.07	432	—	—	—	0.19	0.14	910	—	—	—	0.29	0.22	1416
15	1750	117	0.72	0.58	314	0.46	0.38	206	1.33	1.10	597	0.70	0.61	327	1.91	1.62	875
	1150	76.7	0.56	0.44	362	0.36	0.29	236	1.08	0.87	714	0.65	0.54	441	1.58	1.30	1067
	850	56.7	0.46	0.35	387	0.30	0.23	253	0.89	0.70	781	0.58	0.46	512	1.33	1.06	1184
	690	46.0	0.39	0.29	403	—	—	—	0.78	0.60	819	—	—	—	1.15	0.91	1246
	100	6.7	0.07	0.05	457	—	—	—	0.15	0.10	964	—	—	—	0.23	0.16	1500
20	1750	87.5	0.57	0.45	323	0.35	0.29	207	1.07	0.85	610	0.58	0.46	331	1.54	1.26	906
	1150	57.5	0.44	0.33	364	0.33	0.25	279	0.87	0.67	729	0.53	0.43	468	1.26	1.00	1091
	850	42.5	0.35	0.26	386	0.24	0.18	263	0.73	0.54	799	0.47	0.35	523	1.05	0.81	1199
	690	34.5	0.30	0.22	397	—	—	—	0.64	0.46	834	—	—	—	0.92	0.69	1258
	100	5.0	0.06	0.04	442	—	—	—	0.13	0.08	983	—	—	—	0.18	0.12	1494
25	1750	70.0	0.49	0.36	326	0.29	0.23	200	0.91	0.68	615	0.48	0.37	332	1.29	1.02	916
	1150	46.0	0.38	0.27	371	0.26	0.17	232	0.74	0.53	733	0.46	0.34	461	1.05	0.80	1095
	850	34.0	0.31	0.21	390	0.24	0.14	256	0.62	0.43	804	0.40	0.28	527	0.88	0.65	1200
	690	27.6	0.27	0.17	409	—	—	—	0.54	0.36	839	—	—	—	0.76	0.55	1254
	100	4.0	0.05	0.02	458	—	—	—	0.11	0.06	989	—	—	—	0.16	0.09	1477
30	1750	58.3	0.44	0.30	323	0.27	0.18	199	0.79	0.57	615	0.43	0.30	320	1.13	0.84	906
	1150	38.3	0.35	0.23	372	0.21	0.14	231	0.66	0.45	735	0.39	0.28	456	0.95	0.67	1099
	850	28.3	0.29	0.18	398	0.18	0.12	246	0.56	0.36	804	0.36	0.24	527	0.81	0.55	1215
	690	23.0	0.25	0.15	413	—	—	—	0.49	0.31	841	—	—	—	0.71	0.47	1281
	100	3.3	0.05	0.02	468	—	—	—	0.10	0.05	989	—	—	—	0.15	0.08	1537
40	1750	43.8	0.34	0.22	322	0.19	0.13	188	0.65	0.42	609	0.35	0.23	330	0.90	0.63	906
	1150	28.8	0.27	0.17	362	0.16	0.10	220	0.54	0.33	726	0.34	0.22	476	0.76	0.50	1089
	850	21.3	0.22	0.13	383	0.13	0.07	239	0.46	0.27	794	0.29	0.18	521	0.64	0.40	1194
	690	17.3	0.19	0.11	395	—	—	—	0.40	0.23	831	—	—	—	0.57	0.34	1253
	100	2.5	0.04	0.02	439	—	—	—	0.09	0.04	977	—	—	—	0.12	0.06	1485
50	1750	35.0	0.28	0.17	310	0.13	0.08	142	0.54	0.33	586	0.32	0.20	360	0.74	0.49	876
	1150	23.0	0.23	0.13	349	0.11	0.05	173	0.45	0.26	699	0.31	0.17	458	0.62	0.38	1044
	850	17.0	0.19	0.10	370	0.09	0.05	175	0.39	0.21	765	0.25	0.14	502	0.53	0.31	1142
	690	13.8	0.16	0.08	380	—	—	—	0.35	0.18	800	—	—	—	0.47	0.26	1195
	100	2.0	0.03	0.01	423	—	—	—	0.08	0.03	941	—	—	—	0.10	0.04	1406
60	1750	29.2	0.24	0.14	295	0.11	0.07	142	0.45	0.26	565	0.27	0.15	331	0.64	0.38	818
	1150	19.2	0.19	0.10	331	0.10	0.05	168	0.37	0.20	663	0.25	0.14	468	0.56	0.30	994
	850	14.2	0.16	0.08	351	0.07	0.04	163	0.31	0.16	717	0.23	0.12	528	0.48	0.25	1098
	690	11.5	0.14	0.07	362	—	—	—	0.28	0.14	747	—	—	—	0.43	0.21	1157
	100	1.7	0.03	0.01	401	—	—	—	0.06	0.02	862	—	—	—	0.10	0.04	1390

SIZE 2100 O.P. OHL = 525 LBS.			SIZE 2400 O.P. OHL = 840 LBS.						SIZE 2600 O.P. OHL = 1025 LBS.						SIZE 3200 O.P. OHL = 1365 LBS.				
THERMAL			MECHANICAL			THERMAL			MECHANICAL			THERMAL			MECHANICAL			THERMAL	
I.P. HP	O.P. HP	O.P. TRQ	I.P. HP	O.P. HP	O.P. TRQ	I.P. HP	O.P. HP	O.P. TRQ	I.P. HP	O.P. HP	O.P. TRQ	I.P. HP	O.P. HP	O.P. TRQ	I.P. HP	O.P. HP	O.P. TRQ	I.P. HP	O.P. HP
—	—	—	—	—	—	—	—	—	—	—	—	—	—	—	—	—	—	—	—
—	—	—	—	—	—	—	—	—	—	—	—	—	—	—	—	—	—	—	—
—	—	—	—	—	—	—	—	—	—	—	—	—	—	—	—	—	—	—	—
—	—	—	—	—	—	—	—	—	—	—	—	—	—	—	—	—	—	—	—
—	—	—	—	—	—	—	—	—	—	—	—	—	—	—	—	—	—	—	—
2.32	1.97	371	5.33	5.01	902	3.10	2.92	525	6.60	6.20	1116	3.66	3.37	607	—	—	—	—	—
1.92	1.75	480	4.46	4.14	1134	2.56	2.39	654	5.62	5.21	1427	2.94	2.71	743	—	—	—	—	—
1.82	1.66	615	3.75	3.45	1279	2.16	1.99	738	4.85	4.45	1651	2.64	2.43	902	—	—	—	—	—
—	—	—	3.29	3.00	1369	—	—	—	4.29	3.91	1784	—	—	—	—	—	—	—	—
—	—	—	0.64	0.54	1716	—	—	—	0.89	0.75	2365	—	—	—	—	—	—	—	—
1.43	1.33	479	3.49	3.15	1136	2.30	1.98	712	4.35	3.95	1424	2.53	2.25	812	6.93	6.36	2290	4.29	3.98
1.41	1.13	621	2.89	2.56	1402	1.67	1.49	816	3.63	3.24	1775	2.19	1.97	1082	5.89	5.32	2913	3.43	3.18
1.22	1.06	783	2.42	2.11	1566	1.40	1.23	911	3.05	2.69	1993	1.90	1.71	1268	5.06	4.51	3341	3.04	2.68
—	—	—	2.10	1.81	1656	—	—	—	2.67	2.32	2123	—	—	—	4.47	3.95	3604	—	—
—	—	—	0.41	0.32	2021	—	—	—	0.53	0.42	2634	—	—	—	0.92	0.74	4685	—	—
1.05	0.90	487	2.59	2.27	1229	1.87	1.54	830	3.18	2.73	1474	2.25	1.59	860	5.15	4.56	2465	3.10	2.70
0.98	0.80	660	2.09	1.79	1475	1.41	1.22	1004	2.74	2.28	1872	1.47	1.27	1050	4.39	3.80	3125	2.48	2.15
0.93	0.75	836	1.73	1.45	1617	1.17	0.99	1100	2.37	1.93	2142	1.38	1.16	1285	3.78	3.22	3579	2.26	1.91
—	—	—	1.49	1.24	1693	—	—	—	2.10	1.68	2303	—	—	—	3.35	2.81	3849	—	—
—	—	—	0.28	0.21	2000	—	—	—	0.46	0.31	2961	—	—	—	0.71	0.53	4970	—	—
0.84	0.74	531	2.09	1.75	1261	1.57	1.25	899	2.59	2.18	1568	1.66	1.43	1030	4.08	3.50	2519	2.42	2.18
0.84	0.70	772	1.72	1.40	1529	1.04	0.85	936	2.18	1.78	1947	1.29	1.12	1223	3.51	2.92	3200	1.93	1.73
0.79	0.62	915	1.45	1.14	1692	0.87	0.70	1033	1.85	1.47	2177	1.25	1.03	1534	3.04	2.47	3662	1.83	1.49
—	—	—	1.26	0.98	1784	—	—	—	1.62	1.27	2313	—	—	—	2.70	2.16	3937	—	—
—	—	—	0.25	0.17	2140	—	—	—	0.34	0.23	2842	—	—	—	0.58	0.40	5063	—	—
0.81	0.57	563	1.75	1.40	1258	1.15	0.95	793	2.14	1.78	1598	1.48	1.22	1100	3.41	2.82	2543	1.98	1.63
0.79	0.61	883	1.48	1.13	1548	0.84	0.65	893	1.76	1.41	1930	1.40	1.15	1582	2.95	2.36	3227	1.58	1.30
0.72	0.53	987	1.25	0.93	1719	0.71	0.54	992	1.47	1.15	2123	1.10	0.87	1614	2.56	1.99	3692	1.43	1.18
—	—	—	1.10	0.80	1817	—	—	—	1.27	0.98	2228	—	—	—	2.28	1.74	3969	—	—
—	—	—	0.23	0.14	2205	—	—	—	0.26	0.17	2656	—	—	—	0.50	0.32	5094	—	—
0.60	0.48	523	1.52	1.17	1264	1.09	0.80	856	1.88	1.47	1586	1.10	0.90	975	2.95	2.36	2551	1.65	1.38
0.57	0.46	757	1.28	0.94	1546	0.74	0.55	900	1.60	1.19	1964	0.86	0.70	1158	2.55	1.96	3227	1.32	1.10
0.56	0.39	857	1.09	0.77	1721	0.63	0.45	1001	1.36	0.99	2195	0.82	0.60	1327	2.23	1.66	3692	1.17	0.98
—	—	—	0.96	0.66	1815	—	—	—	1.21	0.85	2332	—	—	—	1.99	1.45	3969	—	—
—	—	—	0.21	0.12	2198	—	—	—	0.26	0.15	2859	—	—	—	0.45	0.27	5094	—	—
0.56	0.38	547	1.21	0.87	1257	0.74	0.50	717	1.49	1.09	1567	0.87	0.65	934	2.33	1.75	2520	1.21	0.97
0.50	0.34	744	1.02	0.70	1527	0.56	0.40	855	1.28	0.88	1940	0.83	0.62	1365	2.04	1.46	3196	0.97	0.77
0.43	0.29	858	0.87	0.57	1688	0.48	0.33	958	1.11	0.73	2173	0.82	0.58	1726	1.79	1.23	3655	0.93	0.74
—	—	—	0.76	0.49	1776	—	—	—	0.98	0.63	2303	—	—	—	1.61	1.08	3929	—	—
—	—	—	0.17	0.08	2130	—	—	—	0.22	0.11	2824	—	—	—	0.38	0.20	5040	—	—
0.48	0.31	558	0.94	0.67	1207	0.59	0.38	689	1.20	0.85	1529	0.83	0.58	1052	1.84	1.37	2461	1.03	0.78
0.43	0.28	767	0.77	0.52	1419	0.42	0.29	799	1.01	0.67	1848	0.73	0.51	1400	1.56	1.11	3031	0.90	0.68
0.40	0.26	964	0.64	0.41	1536	0.34	0.23	845	0.86	0.55	2034	0.70	0.49	1832	1.33	0.91	3368	0.86	0.65
—	—	—	0.55	0.35	1582	—	—	—	0.75	0.47	2139	—	—	—	1.18	0.78	3560	—	—
—	—	—	0.12	0.06	1851	—	—	—	0.17	0.08	2554	—	—	—	0.26	0.14	4337	—	—
0.43	0.20	512	0.82	0.53	1155	0.47	0.30	633	1.04	0.66	1437	0.55	0.37	807	1.50	1.08	2331	0.86	0.60
0.40	0.22	727	0.68	0.42	1377	0.36	0.23	747	0.90	0.54	1777	0.50	0.34	1118	1.26	0.86	2831	0.77	0.54
0.34	0.18	804	0.58	0.34	1506	0.31	0.19	825	0.79	0.45	1987	0.46	0.31	1379	1.08	0.70	3131	0.75	0.48
—	—	—	0.51	0.29	1576	—	—	—	0.70	0.38	2106	—	—	—	0.95	0.60	3293	—	—
—	—	—	0.11	0.05	1853	—	—	—	0.17	0.07	2582	—	—	—	0.21	0.10	3949	—	—

DOUBLE REDUCTION WORM GEAR REDUCER RATING TABLE (1750 RPM)

		SIZE 130000			SIZE 180000			SIZE 210000			SIZE 240000		
		O.P. OHL 219			O.P. OHL 378			O.P. OHL 525			O.P. OHL 840		
RATIO	O.P. RPM	I.P. HP	O.P. HP	O.P. TRQ	I.P. HP	O.P. HP	O.P. TRQ	I.P. HP	O.P. HP	O.P. TRQ	I.P. HP	O.P. HP	O.P. TRQ
75	23.3	0.24	0.16	432	0.50	0.33	899	0.74	0.51	1388	0.93	0.69	1869
80	21.9	0.22	0.14	414	0.49	0.31	896	0.70	0.47	1357	0.97	0.67	1936
100	17.5	0.18	0.12	421	0.41	0.25	914	0.56	0.38	1382	0.77	0.55	1970
120	14.6	0.19	0.10	432	0.38	0.21	903	0.56	0.32	1387	0.75	0.45	1970
125	14.0	0.17	0.10	432	0.28	0.17	774	0.49	0.31	1377	0.72	0.45	2034
150	11.7	0.14	0.08	448	0.29	0.18	945	0.43	0.27	1464	0.54	0.36	1961
160	10.9	0.14	0.07	409	0.32	0.15	887	0.44	0.23	1348	0.60	0.33	1918
200	8.8	0.10	0.06	432	0.24	0.13	957	0.33	0.20	1419	0.47	0.29	2088
225	7.8	0.10	0.06	453	0.22	0.12	956	0.32	0.18	1491	0.39	0.25	1985
240	7.3	0.10	0.04	371	0.22	0.09	795	0.35	0.14	1253	0.40	0.19	1685
250	7.0	0.10	0.05	432	0.21	0.11	963	0.28	0.16	1422	0.43	0.24	2151
300	5.8	0.08	0.04	453	0.17	0.09	961	0.25	0.14	1480	0.32	0.19	1998
375	4.7	0.07	0.03	459	0.15	0.07	958	0.22	0.11	1512	0.27	0.15	2012
400	4.4	0.07	0.03	432	0.14	0.07	979	0.21	0.10	1498	0.28	0.15	2146
450	3.9	0.07	0.03	453	0.14	0.06	972	0.20	0.09	1507	0.24	0.12	2009
500	3.5	0.06	0.02	432	0.13	0.06	990	0.18	0.08	1494	0.24	0.12	2142
600	2.9	0.05	0.02	453	0.11	0.05	972	0.16	0.07	1491	0.22	0.10	2160
750	2.3	0.05	0.02	459	0.10	0.04	972	0.15	0.06	1539	0.20	0.08	2214
800	2.2	0.04	0.02	432	0.09	0.03	979	0.13	0.05	1498	0.18	0.08	2160
900	1.9	0.04	0.01	453	0.09	0.03	972	0.13	0.05	1555	0.18	0.07	2204
1000	1.8	0.04	0.01	432	0.08	0.03	972	0.12	0.04	1512	0.16	0.06	2160
1200	1.5	0.04	0.01	432	0.07	0.02	993	0.10	0.04	1512	0.14	0.05	2160
1250	1.4	0.03	0.01	450	0.08	0.02	945	0.10	0.03	1485	0.15	0.05	2205
1500	1.2	0.03	0.01	432	0.07	0.02	972	0.10	0.03	1566	0.13	0.04	2214
1600	1.1	0.03	0.01	403	0.07	0.02	979	0.09	0.03	1498	0.12	0.04	2132
1800	1.0	0.03	0.01	453	0.06	0.02	972	0.09	0.02	1555	0.12	0.03	2204
2000	0.9	0.02	0.01	432	0.06	0.01	936	0.08	0.02	1440	0.11	0.03	2160
2400	0.7	0.02	0.01	432	0.05	0.01	950	0.07	0.02	1469	0.09	0.03	2160
2500	0.7	0.02	.00	360	0.05	0.01	900	0.07	0.02	1350	0.07	0.02	1800
3000	0.6	0.02	.00	324	0.05	0.01	864	0.06	0.01	1404	0.07	0.02	1836
3600	0.5	0.02	.00	388	0.04	0.01	777	0.06	0.01	1296	0.06	0.01	1815

SD, SCD style double reductions ratings not covered above

RATIO	O.P. RPM	I.P. HP	O.P. HP	O.P. TRQ	O.P. OHL
16	109	0.67	0.54	311	219
20	87.5	0.58	0.46	337	219
25	70.0	0.48	0.38	344	219
40	43.8	0.38	0.27	400	219
50	35.0	0.31	0.22	408	219
60	29.2	0.29	0.19	423	219

SIZE 260000			SIZE 320000			SIZE 380000			SIZE 450000			SIZE 520000			RATIO
O.P. OHL 1025			O.P. OHL 1365			O.P. OHL 1770			O.P. OHL 2160			O.P. OHL 2600			
I.P. HP	O.P. HP	O.P. TRQ	I.P. HP	O.P. HP	O.P. TRQ	I.P. HP	O.P. HP	O.P. TRQ	I.P. HP	O.P. HP	O.P. TRQ	I.P. HP	O.P. HP	O.P. TRQ	
1.42	0.99	2671	2.22	1.65	4475	2.99	2.30	6215	4.29	3.43	9254	6.60	5.12	13837	75
1.26	0.87	2532	---	---	---	---	---	---	---	---	---	---	---	---	80
0.99	0.71	2564	1.72	1.26	4541	2.32	1.75	6295	3.77	2.90	10433	5.76	4.22	15209	100
0.95	0.59	2549	---	---	---	---	---	---	---	---	---	---	---	---	120
0.81	0.55	2467	1.54	1.02	4596	1.80	1.30	5865	2.88	2.12	9535	4.48	3.25	14608	125
0.84	0.53	2868	1.30	0.89	4818	1.75	1.24	6687	2.46	1.85	9978	4.28	3.08	16639	150
0.78	0.43	2518	---	---	---	---	---	---	---	---	---	---	---	---	160
0.62	0.39	2773	1.00	0.65	4710	1.42	0.95	6813	2.30	1.57	11294	3.54	2.38	17121	200
0.63	0.36	2941	0.96	0.61	4934	1.28	0.85	6855	1.82	1.26	10226	3.18	2.11	17059	225
0.57	0.26	2299	---	---	---	---	---	---	---	---	---	---	---	---	240
0.48	0.29	2593	0.84	0.53	4744	1.05	0.69	6230	1.67	1.14	10246	2.69	1.79	16134	250
0.46	0.26	2819	0.77	0.46	4991	1.02	0.64	6925	1.43	0.96	10363	2.54	1.62	17546	300
0.44	0.22	2998	0.65	0.37	5024	0.86	0.52	6982	1.17	0.77	10426	2.02	1.23	16652	375
0.38	0.20	2852	0.63	0.35	5085	0.84	0.49	7058	1.36	0.82	11798	2.13	1.26	18079	400
0.39	0.19	2998	0.59	0.31	5056	0.78	0.43	7001	1.05	0.65	10469	1.78	1.02	16563	450
0.28	0.15	2647	0.54	0.28	5114	0.71	0.40	7112	1.13	0.66	11921	1.61	0.94	16927	500
0.29	0.13	2873	0.49	0.24	5142	0.64	0.33	7152	1.02	0.55	11971	1.49	0.79	17134	600
0.25	0.11	2890	0.42	0.19	5159	0.47	0.24	6455	0.87	0.44	11993	1.20	0.64	17179	750
0.24	0.10	2881	0.40	0.18	5157	0.52	0.25	7174	0.84	0.42	12072	1.33	0.65	18583	800
0.23	0.09	2884	0.38	0.16	5153	0.49	0.22	7195	0.67	0.33	10599	1.03	0.47	15319	900
0.21	0.08	2881	0.34	0.14	5186	0.45	0.20	7202	0.71	0.34	12101	1.00	0.48	17323	1000
0.19	0.07	2895	0.32	0.12	5186	0.42	0.17	7217	0.66	0.28	12144	1.03	0.43	18598	1200
0.16	0.06	2701	0.30	0.12	5222	0.33	0.14	6482	0.50	0.24	10804	0.83	0.39	17377	1250
0.17	0.05	2917	0.27	0.10	5186	0.31	0.12	6482	0.55	0.23	12155	0.79	0.32	17449	1500
0.16	0.05	2823	0.26	0.09	5128	0.34	0.12	7087	0.54	0.21	11986	0.87	0.32	18439	1600
0.15	0.05	2917	0.25	0.08	5186	0.33	0.11	7260	0.51	0.19	12187	0.70	0.27	17308	1800
0.14	0.04	2881	0.23	0.07	5114	0.29	0.10	7130	0.46	0.17	12029	0.74	0.26	18583	2000
0.13	0.03	2852	0.22	0.06	5099	0.27	0.08	7174	0.43	0.14	12014	0.70	0.22	18583	2400
0.11	0.03	2521	0.15	0.05	4411	0.26	0.08	6932	0.31	0.11	10264	0.53	0.18	16567	2500
0.11	0.02	2593	0.15	0.04	4321	0.24	0.06	6914	0.29	0.10	10264	0.50	0.15	16531	3000
0.10	0.02	2593	0.12	0.03	4019	0.21	0.05	6482	0.25	0.08	9724	0.43	0.12	15558	3600

HOW TO ORDER WORM GEAR REDUCERS

PERFECTION GEAR
WORM GEAR REDUCERS

When ordering PLEASE use model number. The examples below may be used to form a model number when the size, ratio and assembly have been determined.

T	A	C	D	18	1200	A
Unit Style	Relative Position (Option)	Motor Code	Other (Options)	Size	Ratio	Shaft Extensions

UNIT STYLE:

See Dimension Pages or Selection Guide Pages 4, 5 & 6.

RELATIVE POSITION INPUT OUTPUT (OPTION):

A - See Dimension Pages.

MOTOR CODE: (For Quil & Coupled Input)

C - 56C Motor Code
L - 140TC Motor Code
G - 180TC Motor Code
W - 210TC Motor Code
Y - Hydraulic Motors

OTHER (OPTIONS):

D - Double Reduction
F - Fan Cooled Option
Z - Alternate Shaft

SIZE:

13 = 1.333 C.D.
18 = 1.750 C.D.
21 = 2.063 C.D.
24 = 2.375 C.D.
26 = 2.625 C.D.
32 = 3.250 C.D.
38 = 3.750 C.D.
45 = 4.500 C.D.
52 = 5.167 C.D.

RATIO (Examples)

Single Reduction	5:1 = 05 60:1 = 60
Double Reduction	75:1 = 0075 400:1 = 0400 3600:1 = 3600

SHAFT EXTENSIONS:

See Assembly Drawing on Dim. Pages

MODEL NUMBER EXAMPLES:

Single Reduction Examples	1)	V	A	C	1	8	3	0	B			
	2)	S	T	F	3	8	6	0	C			
Double Reduction Examples	1)	V	A	C	D	1	8	0	4	0	0	A
	2)	T	L	D	3	2	0	2	2	5	B	

**WORM SHAFT BOTTOM
CAST ON BASE
FAN COOLED OPTIONAL**

STYLE SB-SBF

DIMENSIONS

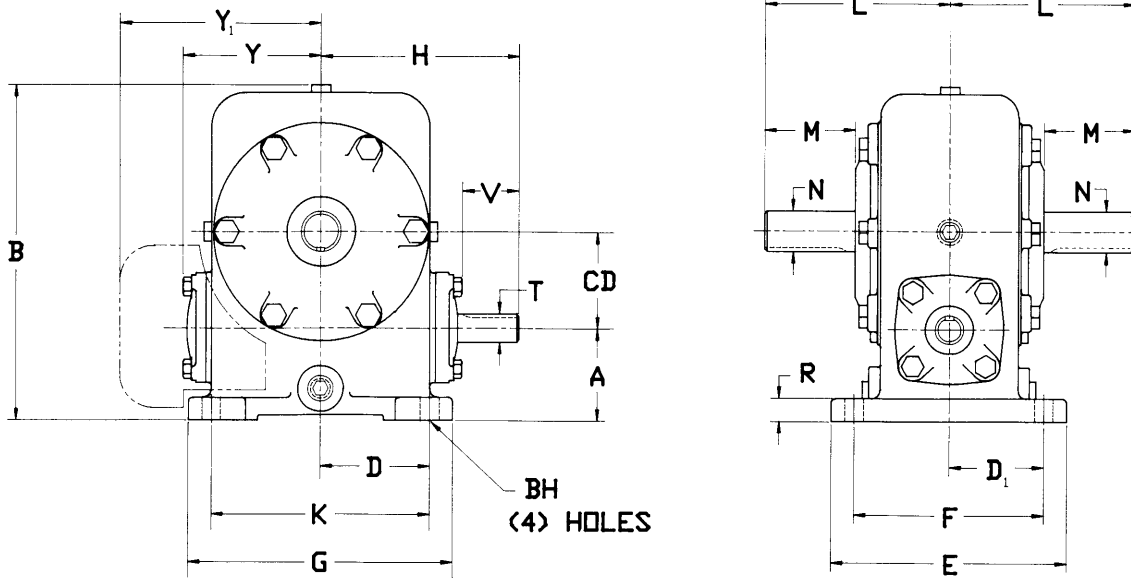

SIZE	C.D.	A	B	D	D ₁	E	F	G	H	K	L	R	Y	Y ₁	BH
1300	1.333	1.50	4.63	1.63	1.63	4.00	3.25	4.00	3.50	3.25	3.25	.38	2.27	---	.281
1800	1.750	1.75	5.63	2.00	1.75	4.50	3.50	5.00	4.00	4.00	3.50	.38	2.65	---	.406
2100	2.063	2.00	7.06	2.38	2.06	5.13	4.13	5.75	4.31	4.75	4.25	.50	3.02	---	.406
2400	2.375	2.25	8.00	2.75	2.06	5.13	4.13	6.50	5.25	5.50	4.06	.56	3.58	---	.406
2600	2.625	2.50	8.63	2.94	2.38	5.75	4.75	7.00	5.63	5.88	5.00	.63	3.71	---	.469
(F)3200	3.250	2.88	10.38	3.75	2.50	6.25	5.00	8.88	6.88	7.50	5.44	.75	4.57	7.13	.531
(F)3800	3.750	3.13	11.44	3.94	2.53	6.38	5.06	9.75	7.50	7.88	6.69	.81	5.07	7.81	.531
(F)4500	4.500	3.63	13.56	4.53	2.75	7.00	5.50	10.75	9.00	9.06	7.25	.88	5.91	8.88	.563
(F)5200	5.167	3.75	14.75	5.13	2.95	7.63	5.91	12.31	10.00	10.25	7.81	.94	6.57	9.63	.688

INPUT SHAFT

SIZE	T	V	KEYWAY
1300	.4990	1.38	.13 × .06
1800	.4990	1.50	.13 × .06
2100	.6240	1.41	.19 × .09
2400	.7490	1.69	.19 × .09
2600	.7490	1.94	.19 × .09
(F)3200	.8740	2.44	.19 × .09
(F)3800	.9990	2.56	.25 × .13
(F)4500	1.1240	3.06	.25 × .13
(F)5200	1.2490	3.47	.25 × .13

OUTPUT SHAFT

M	N	KEYWAY
1.50	.6240	.19 × .09
1.75	.7490	.19 × .09
1.97	.8740	.19 × .09
1.72	.9990	.25 × .13
2.25	1.1240	.25 × .13
2.44	1.2490	.25 × .13
3.00	1.4990	.38 × .19
3.19	1.6240	.38 × .19
3.53	1.7490	.38 × .19

ASSEMBLIES

STYLE SB

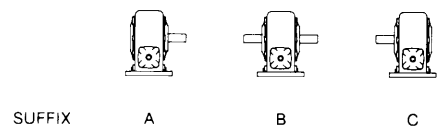

SUFFIX

A

B

C

For ratings see page 12, 13 • For ordering information see page 16 • For motor adapters and couplings see page 61
Dimensions shown are for reference only • Certified prints available upon request • For mounting positions see page 68
Service and maintenance see page 69



STYLE ST-STF

WORM SHAFT TOP
CAST ON BASE
FAN COOLED OPTIONAL

DIMENSIONS

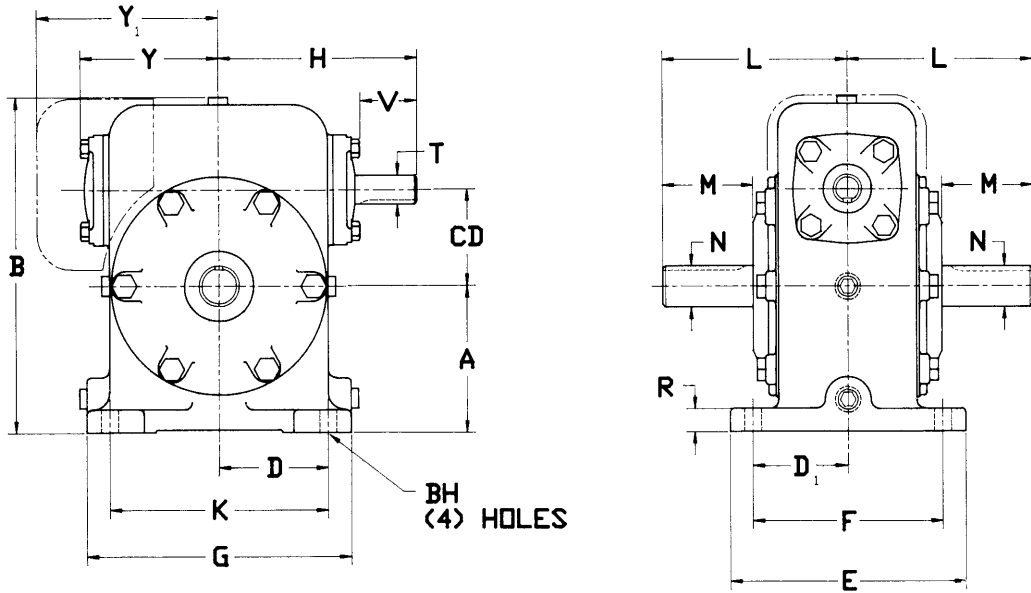

SIZE	C.D.	A	B	D	D ₁	E	F	G	H	K	L	R	Y	Y ₁	BH
1300	1.333	1.88	4.63	1.63	1.63	4.00	3.25	4.00	3.50	3.25	3.25	.38	2.27	---	.281
1800	1.750	2.25	5.63	2.00	1.75	4.50	3.50	5.00	4.00	4.00	3.50	.38	2.65	---	.406
2100	2.063	3.13	7.06	2.38	2.06	5.13	4.13	5.75	4.31	4.75	4.25	.50	3.02	---	.406
2400	2.375	3.50	8.00	2.75	2.06	5.13	4.13	6.50	5.25	5.50	4.06	.56	3.58	---	.406
2600	2.625	3.63	8.63	2.94	2.38	5.75	4.75	7.00	5.63	5.88	5.00	.63	3.71	---	.469
(F)3200	3.250	4.38	10.38	3.75	2.50	6.25	5.00	8.88	6.88	7.50	5.44	.88	4.57	7.13	.531
(F)3800	3.750	4.75	11.44	3.94	2.53	6.38	5.06	9.75	7.50	7.88	6.69	.81	5.07	7.81	.531
(F)4500	4.500	5.50	13.56	4.53	2.75	7.00	5.50	10.75	9.00	9.06	7.25	.88	5.91	8.88	.563
(F)5200	5.167	6.00	14.75	5.13	2.95	7.63	5.91	12.31	10.00	10.25	7.81	.94	6.57	9.63	.688

ASSEMBLIES

STYLE ST

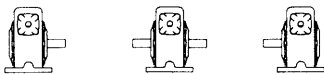

SUFFIX

A

B

C

INPUT SHAFT

SIZE	T	V	KEYWAY
1300	.4990	1.38	.13 × .06
1800	.4990	1.50	.13 × .06
2100	.6240	1.41	.19 × .09
2400	.7490	1.69	.19 × .09
2600	.7490	1.94	.19 × .09
(F)3200	.8740	2.44	.19 × .09
(F)3800	.9990	2.56	.25 × .13
(F)4500	1.1240	3.06	.25 × .13
(F)5200	1.2490	3.47	.25 × .13

OUTPUT SHAFT

M	N	KEYWAY
1.50	.6240	.19 × .09
1.75	.7490	.19 × .09
1.97	.8740	.19 × .09
1.72	.9990	.25 × .13
2.25	1.1240	.25 × .13
2.44	1.2490	.25 × .13
3.00	1.4990	.38 × .19
3.19	1.6240	.38 × .19
3.53	1.7490	.38 × .19

For ratings see page 12, 13 • For ordering information see page 16 • For motor adapters and couplings see page 61
Dimensions shown are for reference only • Certified prints available upon request • For mounting positions see page 68
Service and maintenance see page 69

**CIRCULAR BASE
VERTICAL SHAFT
FAN COOLED OPTIONAL**

STYLE V-VF

DIMENSIONS

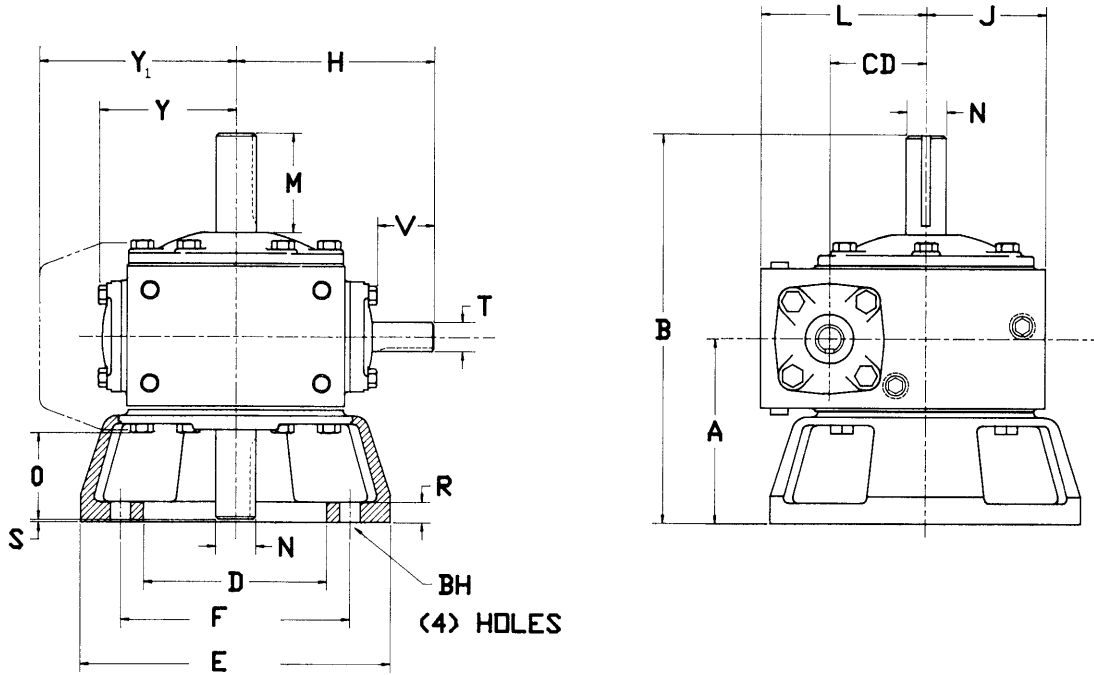

SIZE	C.D.	A	B	D	E	F	H	J	L	R	S	Y	Y ₁	BH
1300	1.333	3.00	6.31	3.38	4.88	4.00	3.50	1.56	2.53	.28	.063	2.27	---	.281
1800	1.750	3.25	6.75	3.63	5.63	4.13	4.00	1.88	3.13	.31	.063	2.65	---	.281
2100	2.063	4.00	8.38	4.00	6.75	5.00	4.31	2.44	3.56	.44	.063	3.02	---	.406
2400	2.375	4.38	8.69	4.63	7.44	5.63	5.25	2.75	4.13	.47	.063	3.58	---	.406
2600	2.625	4.63	9.72	5.50	7.69	6.25	5.63	2.94	4.50	.50	.063	3.71	---	.406
(F)3200	3.250	5.00	10.44	6.00	9.38	7.00	6.88	3.25	5.38	.56	.063	4.57	7.13	.531
(F)3800	3.750	5.38	11.31	6.50	10.50	7.75	7.50	3.94	6.13	.63	.063	5.07	7.81	.531
(F)4500	4.500	6.00	12.91	7.50	12.00	9.00	9.00	5.31	7.97	.63	.063	5.91	8.88	.531
(F)5200	5.167	6.50	13.78	8.50	13.81	10.25	10.00	5.84	8.75	.69	.063	6.57	9.63	.531

INPUT SHAFT

SIZE	T	V	KEYWAY
1300	.4990	1.38	.13 × .06
1800	.4990	1.50	.13 × .06
2100	.6240	1.41	.19 × .09
2400	.7490	1.69	.19 × .09
2600	.7490	1.94	.19 × .09
(F)3200	.8740	2.44	.19 × .09
(F)3800	.9990	2.56	.25 × .13
(F)4500	1.1240	3.06	.25 × .13
(F)5200	1.2490	3.47	.25 × .13

OUTPUT SHAFT

M	N	O	KEYWAY
1.50	.6240	1.38	.19 × .09
1.75	.7490	1.56	.19 × .09
2.09	.8740	1.94	.19 × .09
1.96	.9990	1.66	.25 × .13
2.34	1.1240	2.13	.25 × .13
2.44	1.2490	2.22	.25 × .13
2.23	1.4990	2.25	.38 × .19
2.84	1.6240	2.84	.38 × .19
2.96	1.7490	2.97	.38 × .19

ASSEMBLIES

STYLE V

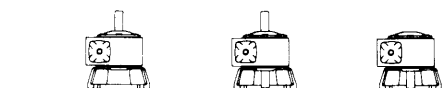

SUFFIX A B C

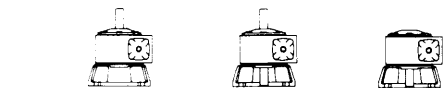

STYLE VA

For ratings see page 12, 13 • For ordering information see page 16 • For motor adapters and couplings see page 61
Dimensions shown are for reference only • Certified prints available upon request • For mounting positions see page 68
Service and maintenance see page 69

STYLE R-RF

HIGH RECTANGULAR BASE
VERTICAL SHAFT
FAN COOLED OPTIONAL

DIMENSIONS

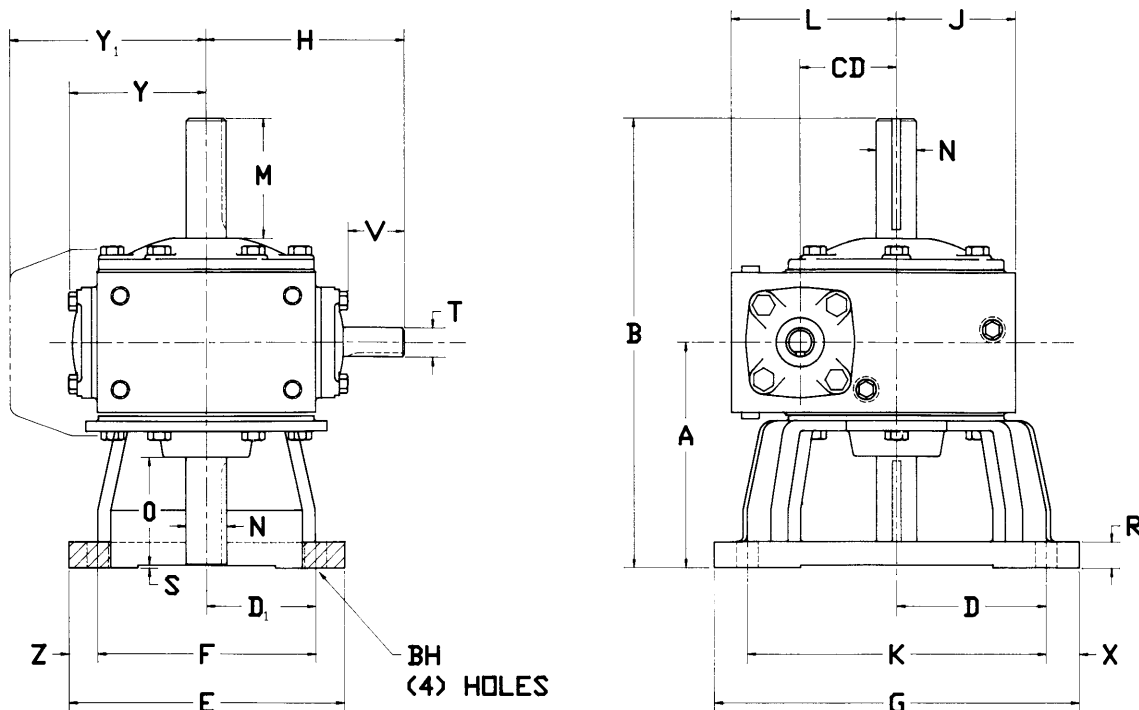

SIZE	C.D.	A	B	D	D ₁	E	F	G	H	J	K	L	R	S	X	Y	Y ₁	Z	BH
1300	1.333	3.56	7.06	2.25	1.69	4.25	3.38	5.50	3.50	1.56	4.50	2.53	.44	.063	.50	2.27	---	.44	.344
1800	1.750	4.38	8.69	2.97	2.16	5.50	4.31	7.19	4.00	1.88	5.94	3.13	.50	.063	.63	2.65	---	.59	.406
2100	2.063	4.88	9.69	3.25	2.38	6.00	4.75	7.94	4.31	2.44	6.50	3.56	.56	.063	.72	3.02	---	.63	.469
2400	2.375	5.25	10.44	3.63	2.69	6.69	5.38	8.69	5.25	2.75	7.25	4.13	.63	.063	.72	3.58	---	.66	.469
2600	2.625	5.59	11.13	4.03	2.97	7.38	5.94	9.69	5.63	2.94	8.06	4.50	.63	.063	.81	3.71	---	.72	.531
(F)3200	3.250	6.25	12.44	4.75	3.56	8.63	7.13	11.19	6.88	3.25	9.50	5.38	.75	.063	.84	4.57	7.13	.75	.531
(F)3800	3.750	7.00	13.94	5.41	4.03	9.75	8.06	12.63	7.50	3.94	10.81	6.13	.81	.063	.91	5.07	7.81	.84	.594
(F)4500	4.500	7.94	15.81	6.13	4.56	11.13	9.13	14.38	9.00	5.31	12.25	7.97	.88	.063	1.06	5.91	8.88	1.00	.656
(F)5200	5.167	8.63	17.19	7.13	5.25	12.75	10.50	16.63	10.00	5.84	14.25	8.75	.94	.063	1.19	6.57	9.63	1.13	.781

ASSEMBLIES

STYLE R

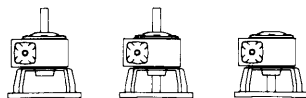

SUFFIX

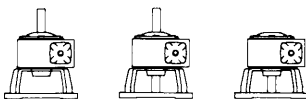

STYLE RA

INPUT SHAFT

SIZE	T	V	KEYWAY
1300	.4990	1.38	.13 × .06
1800	.4990	1.50	.13 × .06
2100	.6240	1.41	.19 × .09
2400	.7490	1.69	.19 × .09
2600	.7490	1.94	.19 × .09
(F)3200	.8740	2.44	.19 × .09
(F)3800	.9990	2.56	.25 × .13
(F)4500	1.1240	3.06	.25 × .13
(F)5200	1.2490	3.47	.25 × .13

OUTPUT SHAFT

M	N	O	KEYWAY
1.75	.6240	1.50	.19 × .09
2.56	.7490	2.34	.19 × .09
2.53	.8740	2.34	.19 × .09
2.84	.9990	2.63	.25 × .13
2.79	1.1240	2.53	.25 × .13
3.17	1.2490	2.97	.25 × .13
3.23	1.4990	3.25	.38 × .19
3.82	1.6240	3.88	.38 × .19
4.25	1.7490	4.25	.38 × .19

For ratings see page 12, 13 • For ordering information see page 16 • For motor adapters and couplings see page 61
Dimensions shown are for reference only • Certified prints available upon request • For mounting positions see page 68
Service and maintenance see page 69

**LOW RECTANGULAR BASE
VERTICAL SHAFT
FAN COOLED OPTIONAL**

STYLE N-NF

DIMENSIONS

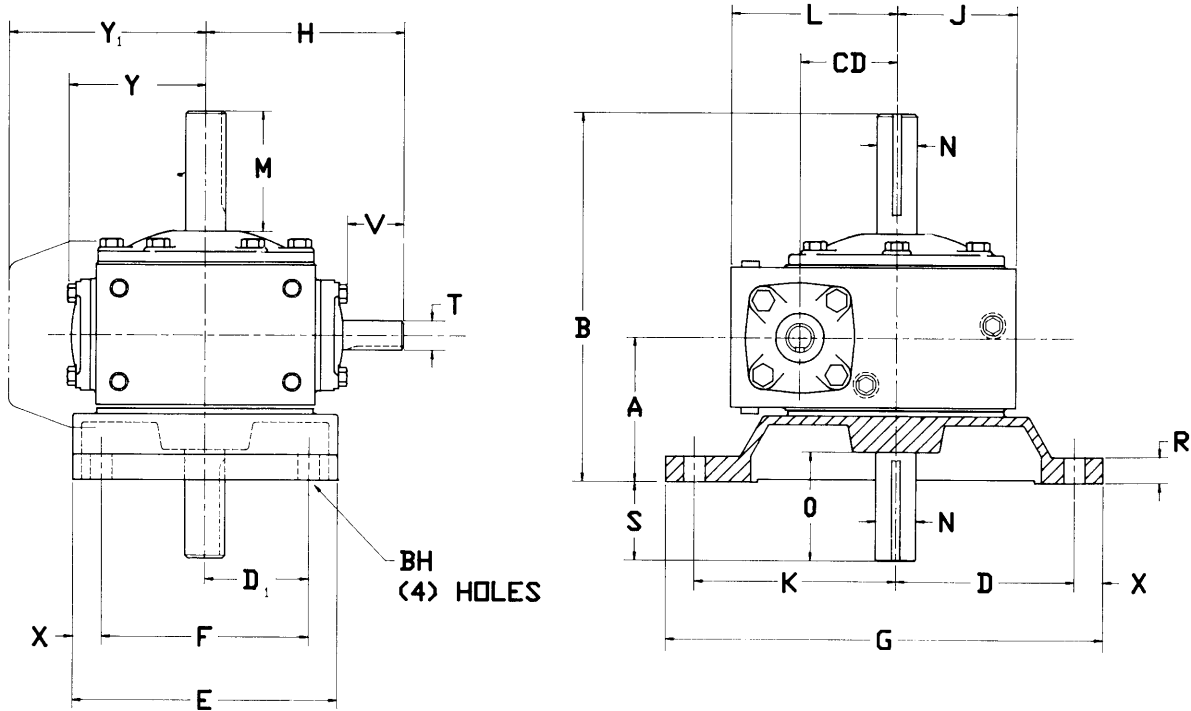

SIZE	C.D.	A	B	D	D ₁	E	F	G	H	J	K	L	R	S	X	Y	Y ₁	BH
1300	1.333	2.31	5.81	2.81	1.50	3.88	3.00	6.88	3.50	1.56	3.19	2.53	.38	1.19	.44	2.27	---	.344
1800	1.750	3.00	7.31	3.50	2.00	5.25	4.00	8.69	4.00	1.88	3.94	3.13	.50	1.31	.63	2.65	---	.406
2100	2.063	3.13	7.94	3.88	2.25	5.75	4.50	9.50	4.31	2.44	4.38	3.56	.56	1.69	.63	3.02	---	.469
2400	2.375	3.38	8.57	4.13	2.50	6.38	5.00	10.25	5.25	2.75	4.75	4.13	.63	1.81	.69	3.58	---	.469
2600	2.625	3.63	9.15	4.63	2.88	7.25	5.75	11.50	5.63	2.94	5.38	4.50	.69	1.91	.75	3.71	---	.531
(F)3200	3.250	4.69	10.88	5.25	3.63	8.75	7.25	13.13	6.88	3.25	6.38	5.38	.75	1.50	.75	4.57	7.13	.531
(F)3800	3.750	5.25	12.19	5.88	4.13	10.00	8.25	14.88	7.50	3.94	7.25	6.13	.81	1.69	.88	5.07	7.81	.594
(F)4500	4.500	5.63	13.50	6.88	4.75	11.50	9.50	17.13	9.00	5.31	8.25	7.97	.88	2.25	1.00	5.91	8.88	.656
(F)5200	5.167	6.38	14.94	7.63	5.38	13.00	10.75	19.13	10.00	5.84	9.25	8.75	.94	2.19	1.13	6.57	9.63	.781

INPUT SHAFT

SIZE	T	V	KEYWAY
1300	.4990	1.38	.13 × .06
1800	.4990	1.50	.13 × .06
2100	.6240	1.41	.19 × .09
2400	.7490	1.69	.19 × .09
2600	.7490	1.94	.19 × .09
(F)3200	.8740	2.44	.19 × .09
(F)3800	.9990	2.56	.25 × .13
(F)4500	1.1240	3.06	.25 × .13
(F)5200	1.2490	3.47	.25 × .13

OUTPUT SHAFT

M	N	O	KEYWAY
1.75	.6240	1.50	.19 × .09
2.56	.7490	2.31	.19 × .09
2.53	.8740	2.34	.19 × .09
2.81	.9990	2.63	.25 × .13
2.79	1.1240	2.53	.25 × .13
3.17	1.2490	2.97	.25 × .13
3.23	1.4990	3.25	.38 × .19
3.82	1.6240	3.88	.38 × .19
4.25	1.7490	4.25	.38 × .19

ASSEMBLIES

STYLE N

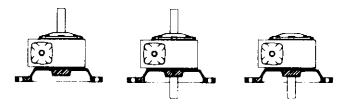

SUFFIX

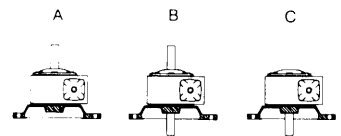

STYLE NA

For ratings see page 12, 13 • For ordering information see page 16 • For motor adapters and couplings see page 61
Dimensions shown are for reference only • Certified prints available upon request • For mounting positions see page 68
Service and maintenance see page 69

STYLE T*-T*F

WORM SHAFT TOP
 QUILLED C-FACE INPUT
 CAST ON BASE
 FAN COOLED OPTIONAL

DIMENSIONS

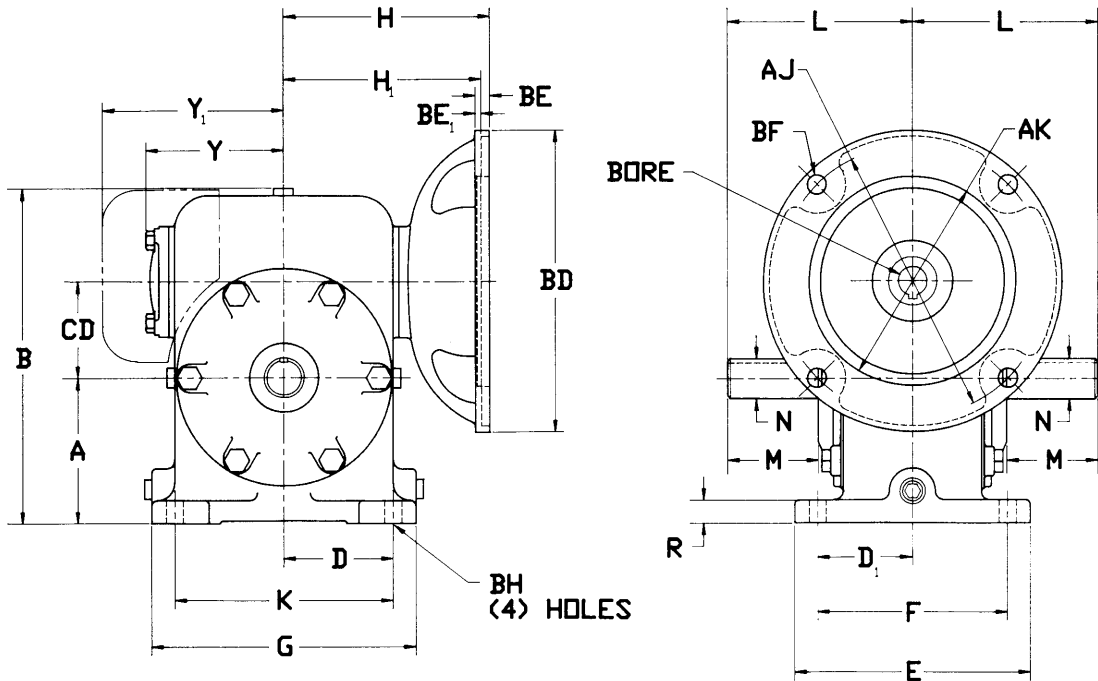

SIZE	C.D.	A	B	D	D ₁	E	F	G	H	H ₁	K	L	R	Y	Y ₁	BH
1300	1.333	1.88	4.63	1.63	1.63	4.00	3.25	4.00	3.73	---	3.25	3.25	.38	2.51	---	.281
1800	1.750	2.25	5.63	2.00	1.75	4.50	3.50	5.00	4.11	---	4.00	3.50	.38	2.88	---	.406
2100	2.063	3.13	7.06	2.38	2.06	5.13	4.13	5.75	4.48	---	4.75	4.25	.50	3.16	---	.406
2400	2.375	3.50	8.00	2.75	2.06	5.13	4.13	6.50	4.98	---	5.50	4.06	.56	3.57	---	.406
2600	2.625	3.63	8.63	2.94	2.38	5.75	4.75	7.00	5.11	---	5.88	5.00	.63	3.69	---	.469
(F)3200	3.250	4.38	10.38	3.75	2.50	6.25	5.00	8.88	5.85	5.60	7.50	5.44	.88	4.55	7.13	.531
(F)3800	3.750	4.75	11.44	3.94	2.53	6.38	5.06	9.75	6.35	6.10	7.88	6.69	.81	5.05	7.81	.531
(F)4500	4.500	5.50	13.56	4.53	2.75	7.00	5.50	10.75	7.13	6.88	9.06	7.25	.88	5.90	8.88	.563
(F)5200	5.167	6.00	14.75	5.13	2.95	7.63	5.91	12.31	7.79	7.53	10.25	7.81	.94	6.55	9.63	.688

ASSEMBLIES

STYLE T*



SUFFIX A B C

OUTPUT SHAFT

SIZE	M	N	KEYWAY
1300	1.50	.6240	.19 X .09
1800	1.75	.7490	.19 X .09
2100	1.97	.8740	.19 X .09
2400	1.72	.9990	.25 X .13
2600	2.25	1.1240	.25 X .13
(F)3200	2.44	1.2490	.25 X .13
(F)3800	3.00	1.4990	.38 X .19
(F)4500	3.19	1.6240	.38 X .19
(F)5200	3.53	1.7490	.38 X .19

*MOTOR FLANGE DIMENSIONS

MOTOR FRAME	AJ	AK	BD	BE	BE ₁	BF	BORE	KEYWAY
C = 56C	5.88	4.50	6.50	.31	---	.422	.6260	.19 X .09
L = 143TC 145TC	5.88	4.50	6.50	.31	---	.422	.8760	.19 X .09
G = 182TC 184TC	7.25	8.50	8.91	---	.38	.531	1.1260	.25 X .12
W = 213TC 215TC	7.25	8.50	8.91	---	.38	.531	1.3760	.31 X .15

H₁ for 182TC, 184TC, 213TC, 215TC

For ratings see page 12, 13 • For ordering information see page 16
 Dimensions shown are for reference only • Certified prints available upon request • For mounting positions see page 68
 Service and maintenance see page 69

**CIRCULAR BASE
QUILLED C-FACE INPUT
VERTICAL SHAFT
FAN COOLED OPTIONAL**

STYLE V*-V*F

DIMENSIONS

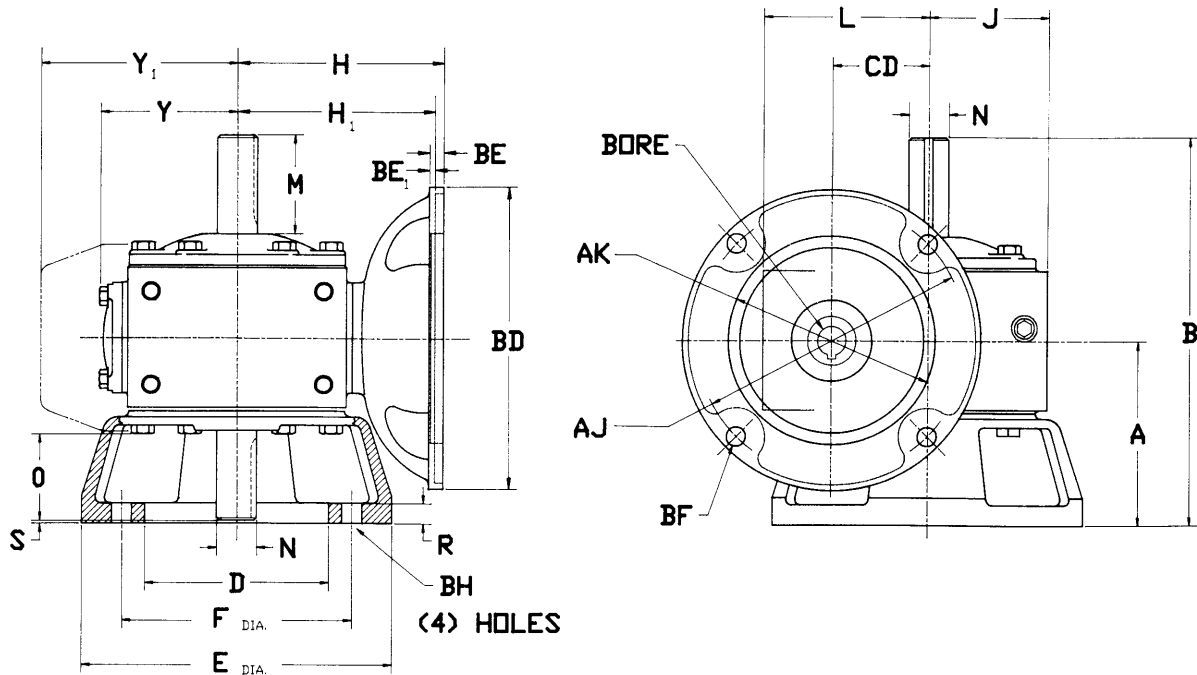

SIZE	C.D.	A	B	D	E	F	H	H ₁	J	L	R	S	Y	Y ₁	BH
1300	1.333	3.00	6.31	3.38	4.88	4.00	3.73	---	1.56	2.53	.28	.063	2.51	---	.281
1800	1.750	3.25	6.75	3.63	5.63	4.13	4.12	---	1.88	3.13	.31	.063	2.88	---	.281
2100	2.063	4.00	8.38	4.00	6.75	5.00	4.48	---	2.44	3.56	.44	.063	3.16	---	.406
2400	2.375	4.38	8.68	4.63	7.44	5.63	4.98	---	2.75	4.13	.47	.063	3.57	---	.406
2600	2.625	4.63	9.72	5.50	7.69	6.25	5.10	---	2.94	4.50	.50	.063	3.69	---	.406
(F)3200	3.250	5.00	10.44	6.00	9.38	7.00	5.85	5.60	3.25	5.38	.56	.063	4.55	7.13	.531
(F)3800	3.750	5.38	11.31	6.50	10.50	7.75	6.35	6.10	3.94	6.13	.63	.063	5.05	7.81	.531
(F)4500	4.500	6.00	12.91	7.50	12.00	9.00	7.13	6.88	5.31	7.97	.63	.063	5.90	8.88	.531
(F)5200	5.167	6.50	13.78	8.50	13.81	10.25	7.79	7.53	5.84	8.75	.69	.063	6.55	9.63	.531

OUTPUT SHAFT

SIZE	M	N	O	KEYWAY
1300	1.50	.6240	1.38	.19 X .09
1800	1.75	.7490	1.56	.19 X .09
2100	2.09	.8740	1.94	.19 X .09
2400	1.96	.9990	1.66	.25 X .13
2600	2.34	1.1240	2.13	.25 X .13
(F)3200	2.44	1.2490	2.22	.25 X .13
(F)3800	2.23	1.4990	2.25	.38 X .19
(F)4500	2.84	1.6240	2.84	.38 X .19
(F)5200	2.96	1.7490	2.97	.38 X .19

ASSEMBLIES

STYLE V*

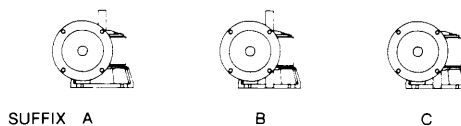

STYLE VA*

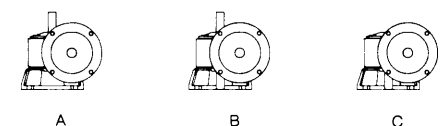

*MOTOR FLANGE DIMENSIONS

MOTOR FRAME	AJ	AK	BD	BE	BE ₁	BF	BORE	KEYWAY
C = 56C	5.88	4.50	6.50	.31	---	.422	.6260	.19 X .09
L = 143TC 145TC	5.88	4.50	6.50	.31	---	.422	.8760	.19 X .09
G = 182TC 184TC	7.25	8.50	8.91	---	.38	.531	1.1260	.25 X .12
W = 213TC 215TC	7.25	8.50	8.91	---	.38	.531	1.3760	.31 X .15

H₁ for 182TC, 184TC, 213TC, 215TC

For ratings see page 12, 13 • For ordering information see page 16
Dimensions shown are for reference only • Certified prints available upon request • For mounting positions see page 68
Service and maintenance see page 69



STYLE R*-R*F

HIGH RECTANGULAR BASE
QUILLED C-FACE INPUT
VERTICAL SHAFT
FAN COOLED OPTIONAL

DIMENSIONS

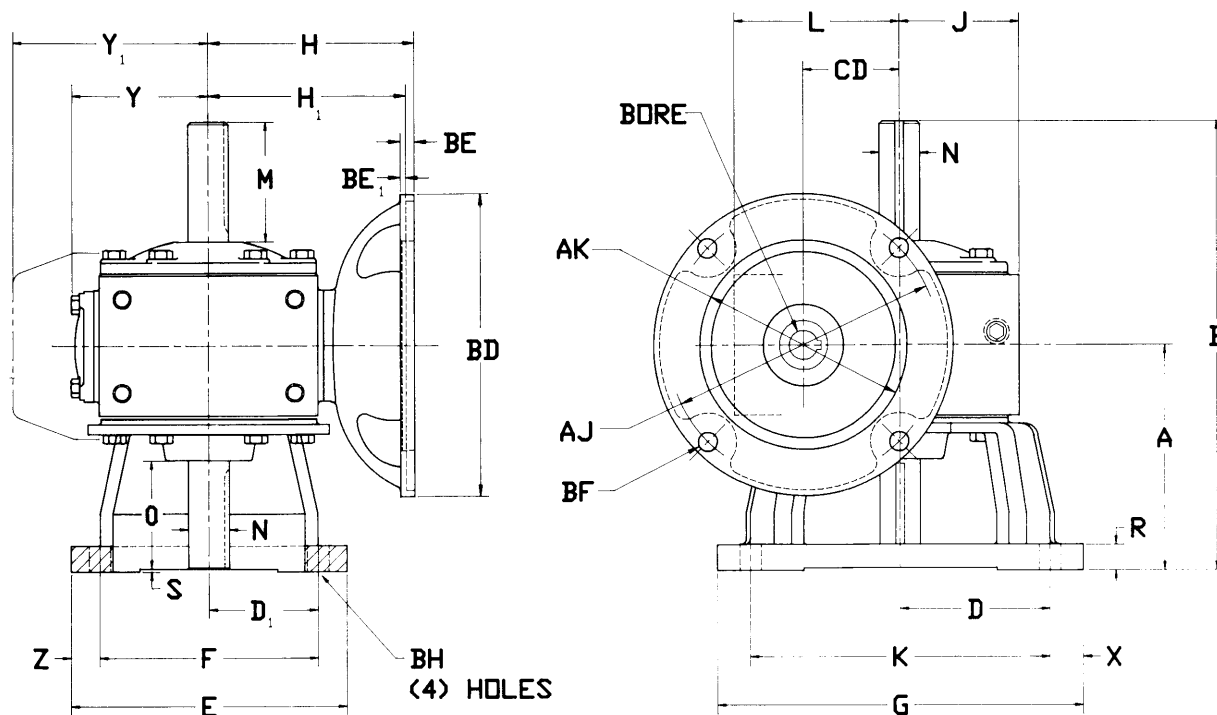

SIZE	C.D.	A	B	D	D ₁	E	F	G	H	H ₁	J	K	L	R	S	X	Y	Y ₁	Z	BH
1300	1.333	3.56	7.06	2.25	1.69	4.25	3.38	5.50	3.73	---	1.56	4.50	2.53	.44	.063	.50	2.51	---	.44	.344
1800	1.750	4.38	8.69	2.97	2.16	5.50	4.31	7.19	4.12	---	1.88	5.94	3.13	.50	.063	.63	2.88	---	.59	.406
2100	2.063	4.88	9.69	3.25	2.38	6.00	4.75	7.94	4.48	---	2.44	6.50	3.56	.56	.063	.72	3.16	---	.63	.469
2400	2.375	5.25	10.44	3.63	2.69	6.69	5.38	8.69	4.98	---	2.75	7.25	4.13	.63	.063	.72	3.57	---	.66	.469
2600	2.625	5.59	11.13	4.03	2.97	7.38	5.94	9.69	5.10	---	2.94	8.06	4.50	.63	.063	.81	3.69	---	.72	.531
(F)3200	3.250	6.25	12.44	4.75	3.56	8.63	7.13	11.19	5.85	5.60	3.25	9.50	5.38	.75	.063	.84	4.55	7.13	.75	.531
(F)3800	3.750	7.00	13.94	5.41	4.03	9.75	8.06	12.63	6.35	6.10	3.94	10.81	6.72	.81	.063	.91	5.05	7.81	.84	.594
(F)4500	4.500	7.94	15.81	6.13	4.56	11.13	9.13	14.38	7.13	6.88	5.31	12.25	7.97	.88	.063	1.06	5.90	8.88	1.00	.656
(F)5200	5.167	8.63	17.19	7.13	5.25	12.75	10.50	16.63	7.79	7.53	5.84	14.25	8.75	.94	.063	1.19	6.55	9.63	1.13	.781

ASSEMBLIES

STYLE R*

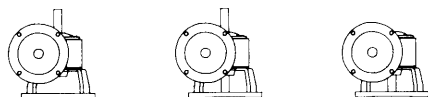

SUFFIX A B C

STYLE RA*

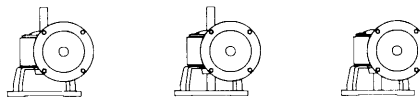

A B C

OUTPUT SHAFT

SIZE	M	N	O	KEYWAY
1300	1.75	.6240	1.50	.19 X .09
1800	2.56	.7490	2.34	.19 X .09
2100	2.53	.8740	2.34	.19 X .09
2400	2.84	.9990	2.63	.25 X .13
2600	2.79	1.1240	2.53	.25 X .13
(F)3200	3.17	1.2490	2.97	.25 X .13
(F)3800	3.23	1.4990	3.25	.38 X .19
(F)4500	3.82	1.6240	3.88	.38 X .19
(F)5200	4.25	1.7490	4.25	.38 X .19

*MOTOR FLANGE DIMENSIONS

MOTOR FRAME	AJ	AK	BD	BE	BE ₁	BF	BORE	KEYWAY
C = 56C	5.88	4.50	6.50	.31	---	.422	.6260	.19 X .09
L = 143TC 145TC	5.88	4.50	6.50	.31	---	.422	.8760	.19 X .09
G = 182TC 184TC	7.25	8.50	8.91	---	.38	.531	1.1260	.25 X .12
W = 213TC 215TC	7.25	8.50	8.91	---	.38	.531	1.3760	.31 X .15

H₁ for 182TC, 184TC, 213TC, 215TC

For ratings see page 12, 13 • For ordering information see page 16
Dimensions shown are for reference only • Certified prints available upon request • For mounting positions see page 68
Service and maintenance see page 69

**LOW RECTANGULAR BASE
QUILLED C-FACE INPUT
VERTICAL SHAFT
FAN COOLED OPTIONAL**

STYLE N*-N*F

DIMENSIONS

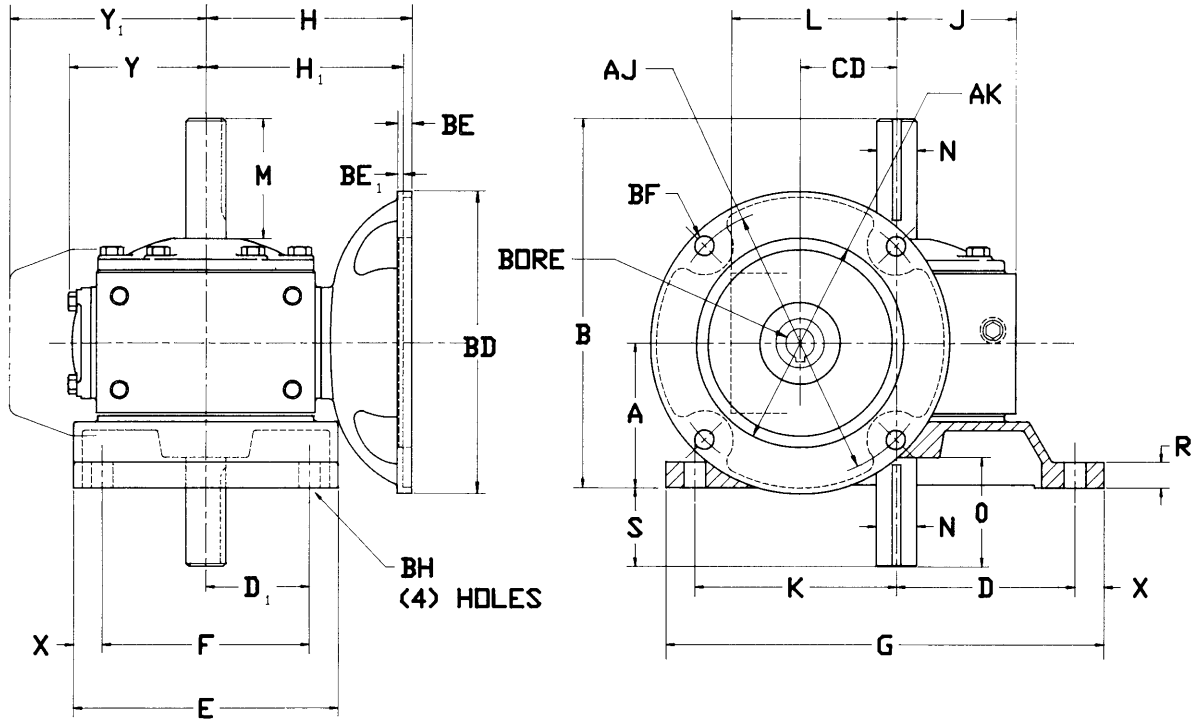

SIZE	C.D.	A	B	D	D ₁	E	F	G	H	H ₁	J	K	L	R	S	X	Y	Y ₁	BH
1300	1.333	2.31	5.81	2.81	1.50	3.88	3.00	6.88	3.73	---	1.56	3.19	2.53	.38	1.19	.44	2.51	---	.344
1800	1.750	3.00	7.31	3.50	2.00	5.25	4.00	8.69	4.12	---	1.88	3.94	3.13	.50	1.31	.63	2.88	---	.406
2100	2.063	3.13	7.94	3.88	2.25	5.75	4.50	9.50	4.48	---	2.44	4.38	3.56	.56	1.69	.63	3.16	---	.469
2400	2.375	3.38	8.57	4.13	2.50	6.38	5.00	10.25	4.98	---	2.75	4.75	4.13	.63	1.81	.69	3.57	---	.469
2600	2.625	3.63	9.15	4.63	2.88	7.25	5.75	11.50	5.10	---	2.94	5.38	4.50	.69	1.91	.75	3.69	---	.531
(F)3200	3.250	4.69	10.88	5.25	3.63	8.75	7.25	13.13	5.85	5.60	3.25	6.38	5.38	.75	1.50	.75	4.55	7.13	.531
(F)3800	3.750	5.25	12.19	5.88	4.13	10.00	8.25	14.88	6.35	6.10	3.94	7.25	6.13	.81	1.69	.88	5.05	7.81	.594
(F)4500	4.500	5.63	13.50	6.88	4.75	11.50	9.50	17.13	7.13	6.88	5.31	8.25	7.97	.88	2.25	1.00	5.90	8.88	.656
(F)5200	5.167	6.38	14.94	7.63	5.38	13.00	10.75	19.13	7.79	7.53	5.84	9.25	8.75	.94	2.19	1.13	6.55	9.63	.781

OUTPUT SHAFT

SIZE	M	N	O	KEYWAY
1300	1.75	.6240	1.50	.19 X .09
1800	2.56	.7490	2.31	.19 X .09
2100	2.53	.8740	2.34	.19 X .09
2400	2.81	.9990	2.63	.25 X .13
2600	2.79	1.1240	2.53	.25 X .13
(F)3200	3.17	1.2490	2.97	.25 X .13
(F)3800	3.23	1.4990	3.25	.38 X .19
(F)4500	3.82	1.6240	3.88	.38 X .19
(F)5200	4.25	1.7490	4.25	.38 X .19

ASSEMBLIES

STYLE N*

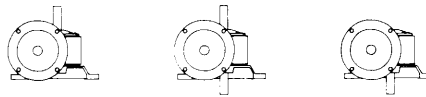

SUFFIX A

B

C

STYLE NA*

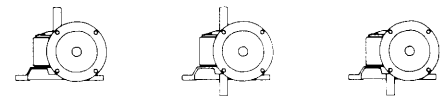

A

B

C

*MOTOR FLANGE DIMENSIONS

MOTOR FRAME	AJ	AK	BD	BE	BE ₁	BF	BORE	KEYWAY
C = 56C	5.88	4.50	6.50	.31	---	.422	.6260	.19 X .09
L = 143TC 145TC	5.88	4.50	6.50	.31	---	.422	.8760	.19 X .09
G = 182TC 184TC	7.25	8.50	8.91	---	.38	.531	1.1260	.25 X .12
W = 213TC 215TC	7.25	8.50	8.91	---	.38	.531	1.3760	.31 X .15

H₁ for 182TC, 184TC, 213TC, 215TC

For ratings see page 12, 13 • For ordering information see page 16
Dimensions shown are for reference only • Certified prints available upon request • For mounting positions see page 68
Service and maintenance see page 69



STYLE MT*

WORM SHAFT TOP
COUPLED C-FACE INPUT
CAST ON BASE

DIMENSIONS

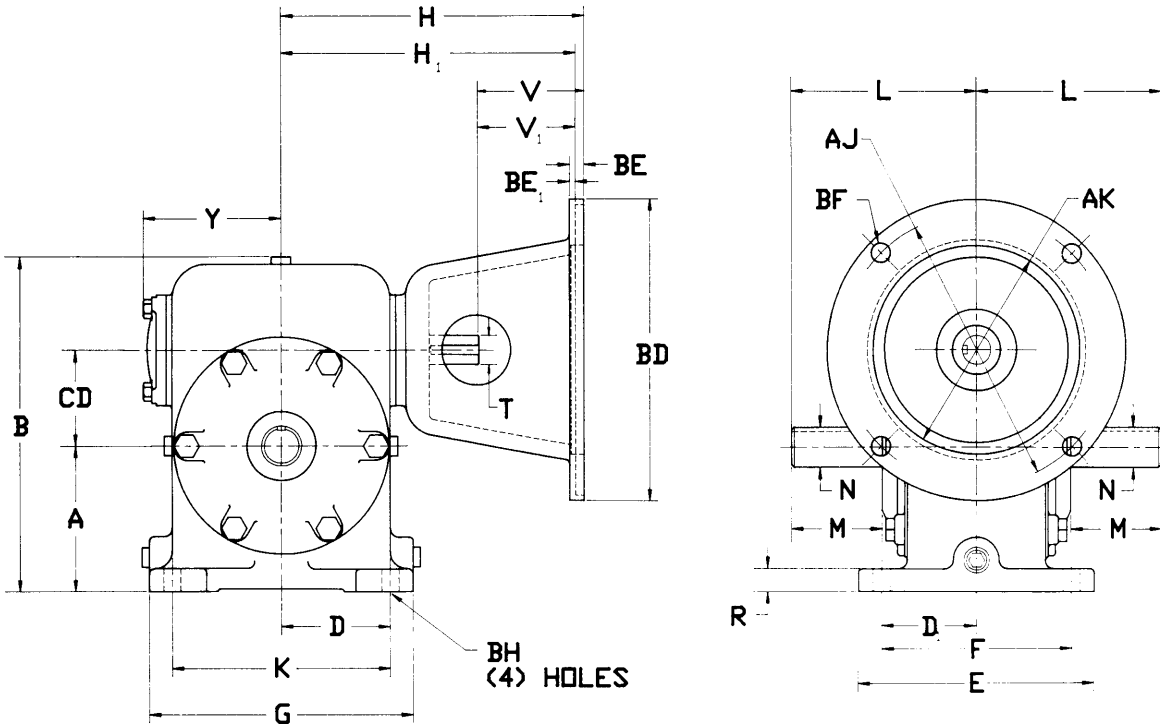

SIZE	C.D.	A	B	D	D ₁	E	F	G	H	H ₁	K	L	R	Y	BH
1300	1.333	1.88	4.63	1.63	1.63	4.00	3.25	4.00	5.91	---	3.25	3.25	.38	2.27	.281
1800	1.750	2.25	5.63	2.00	1.75	4.50	3.50	5.00	6.29	---	4.00	3.50	.38	2.65	.406
2100	2.063	3.13	7.06	2.38	2.06	5.13	4.13	5.75	6.60	---	4.75	4.25	.50	3.02	.406
2400	2.375	3.50	8.00	2.75	2.06	5.13	4.13	6.50	7.79	7.51	5.50	4.06	.56	3.50	.406
2600	2.625	3.63	8.63	2.94	2.36	5.75	4.75	7.00	7.91	7.63	5.80	5.00	.63	3.71	.469
(F)3200	3.250	4.38	10.38	3.75	2.50	6.25	5.00	8.88	9.25	10.25	7.50	5.44	.88	4.55	.531
(F)3800	3.750	4.75	11.44	3.94	2.53	6.38	5.06	9.75	9.75	10.75	7.88	6.69	.81	5.05	.531
(F)4500	4.500	5.50	13.56	4.53	2.75	7.00	5.50	10.75	11.56	12.56	9.06	7.25	.88	5.90	.563
(F)5200	5.167	6.00	14.75	5.13	2.95	7.63	5.91	12.31	12.22	13.22	10.25	7.81	.94	6.55	.688



SUFFIX

A

B

C

INPUT SHAFT

SIZE	T	V	V ₁	KEYWAY
1300	.4990	2.41	---	.13 x .06
1800	.4990	2.29	---	.13 x .06
2100	.6240	2.29	---	.19 x .09
2400	.7490	2.53	2.90	.19 x .09
2600	.7490	2.29	2.93	.19 x .09
(F)3200	.8740	2.37	3.37	.19 x .09
(F)3800	.9990	2.25	3.25	.25 x .13
(F)4500	1.1240	2.56	3.56	.25 x .13
(F)5200	1.2490	2.22	3.22	.25 x .13

OUTPUT SHAFT

M	N	KEYWAY
1.50	.6240	.19 x .09
1.75	.7490	.19 x .09
1.97	.8740	.19 x .09
1.72	.9990	.25 x .13
2.25	1.1240	.25 x .13
2.44	1.2490	.25 x .13
3.00	1.4990	.38 x .19
2.97	1.6240	.38 x .19
3.53	1.7490	.38 x .19

*MOTOR FLANGE DIMENSIONS

MOTOR FRAME	AJ	AK	BD	BE	BE ₁	BF
C = 56C	5.88	4.50	6.50	.41	---	.406
L = 143TC 145TC	5.88	4.50	6.50	.41	---	.406
G = 182TC 184TC	7.25	8.50	9.00	---	.22	.531

H₁ and V₁ FOR 182TC, 184TC ONLY

For ratings see page 12, 13 • For ordering information see page 16 • For couplings see page 61
Dimensions shown are for reference only • Certified prints available upon request • For mounting positions see page 68
Service and maintenance see page 69

DIMENSIONS

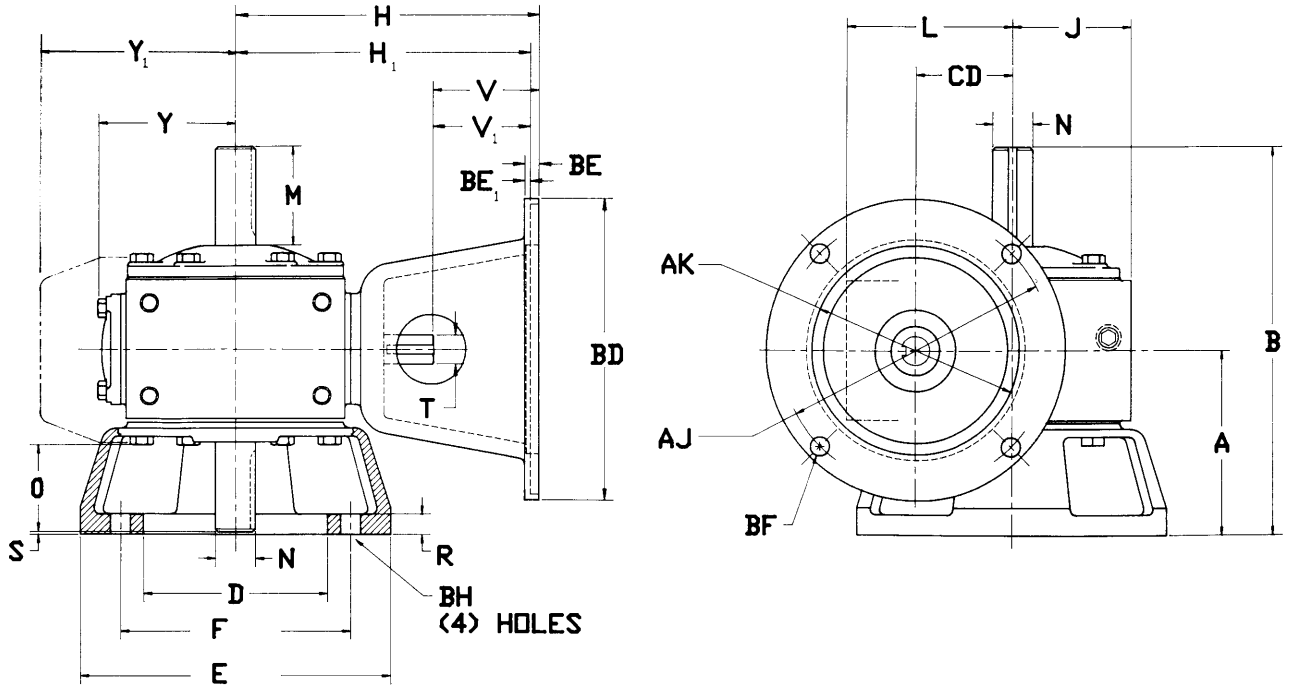

SIZE	C.D.	A	B	D	E	F	H	H ₁	J	L	R	S	Y	Y ₁	BH
1300	1.333	3.00	6.31	3.38	4.88	4.00	5.91	—	1.56	2.53	0.28	0.063	2.27	—	0.281
1800	1.750	3.25	6.75	3.63	5.63	4.13	6.29	—	1.88	3.13	0.31	0.063	2.65	—	0.281
2100	2.063	4.00	8.38	4.00	6.75	5.00	6.60	—	2.44	3.56	0.44	0.063	3.02	—	0.406
2400	2.375	4.38	8.69	4.63	7.44	5.63	7.79	7.51	2.75	4.13	0.47	0.063	3.58	—	0.406
2600	2.625	4.63	9.72	5.50	7.69	6.25	7.91	7.63	2.94	4.50	0.50	0.063	3.71	—	0.406
(F) 3200	3.250	5.00	10.44	6.00	9.38	7.00	9.25	10.25	3.25	5.38	0.56	0.063	4.55	7.13	0.531
(F) 3800	3.750	5.38	11.31	6.50	10.50	7.75	9.75	10.75	3.94	6.13	0.63	0.063	5.05	7.81	0.531
(F) 4500	4.500	6.00	12.91	7.50	12.00	9.00	11.56	12.56	5.31	7.97	0.63	0.063	5.90	8.88	0.531
(F) 5200	5.167	6.50	13.78	8.50	13.81	10.25	12.22	13.22	5.84	8.75	0.69	0.063	6.55	9.63	0.531

INPUT SHAFT

SIZE	T	V	V ₁	KEYWAY
1300	0.4990	2.41	—	.13 x .06
1800	0.4990	2.29	—	.13 x .06
2100	0.6240	2.29	—	.19 x .09
2400	0.7490	2.53	2.90	.19 x .09
2600	0.7490	2.29	2.93	.19 x .09
(F) 3200	0.8740	2.37	3.37	.19 x .09
(F) 3800	0.9990	2.25	3.25	.25 x .13
(F) 4500	1.1240	2.56	3.56	.25 x .13
(F) 5200	1.2490	2.22	3.22	.25 x .13

OUTPUT SHAFT

M	N	O	KEYWAY
1.50	0.6240	1.38	.19 x .09
1.75	0.7490	1.56	.19 x .09
1.97	0.8740	1.94	.19 x .09
1.72	0.9990	1.66	.25 x .13
2.25	1.1240	2.13	.25 x .13
2.44	1.2490	2.22	.25 x .13
3.00	1.4990	2.25	.38 x .19
2.97	1.6240	2.84	.38 x .19
3.53	1.7490	2.97	.38 x .19

ASSEMBLIES

STYLE MV*

SUFFIX

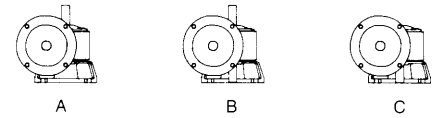

STYLE MVA*

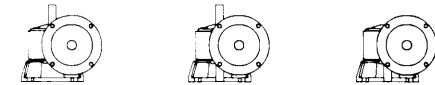

For ratings see page 12, 13 • For ordering information see page 16
For couplings see page 61 • Dimensions shown are for reference only
Certified prints available upon request • For mounting positions see
page 68 • Service and maintenance see page 69

MOTOR FLANGE DIMENSIONS

MOTOR FRAME	AJ	AK	BD	BE	BE ₁	BF	BORE	KEYWAY
C = 56C	5.88	4.50	6.50	0.41	0.531	—	0.406	—
L = 143TC = 145TC	5.88	4.50	6.50	0.41	0.531	—	0.406	—

MOTOR FRAME	AJ	AK	BD	BE	BE ₁	BF	BORE	KEYWAY
G = 182TC = 184TC	7.25	8.50	9.00	—	0.22	—	0.531	—
W = 213TC = 215TC	7.25	8.50	8.91	—	0.38	0.531	1.3760	.31 x .15

STYLE MR*-MRA*

HIGH RECTANGULAR BASE
VERTICAL SHAFT
COUPLED C-FACE INPUT

DIMENSIONS

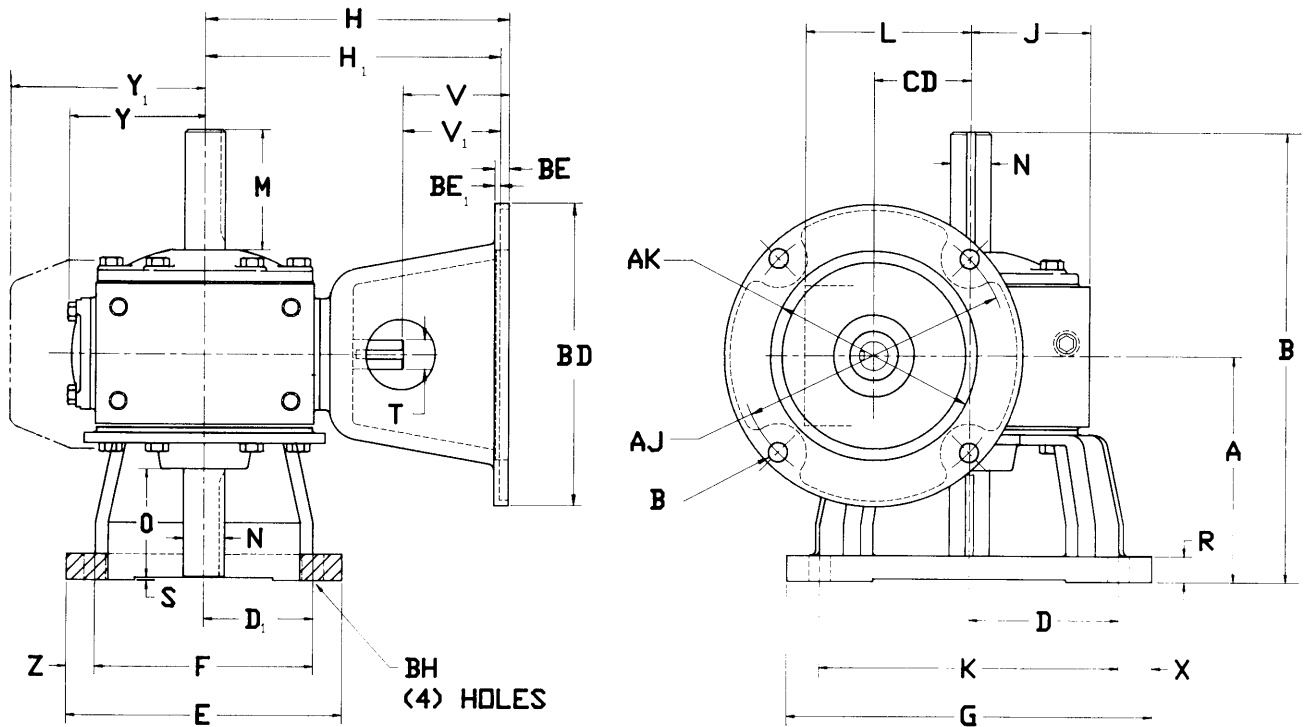

SIZE	C.D.	A	B	D	D ₁	E	F	G	H	H ₁	J	K	L	R	S	X	Y	Y ₁	Z	BH
1300	1.333	3.56	7.06	2.25	1.69	4.25	3.38	5.50	5.91	—	1.56	4.50	2.53	0.44	0.063	0.50	2.27	—	0.44	0.344
1800	1.750	4.38	8.69	2.97	2.16	5.50	4.31	7.19	6.29	—	1.88	5.94	3.13	0.50	0.063	0.63	2.65	—	0.59	0.406
2100	2.063	4.88	9.69	3.25	2.38	6.00	4.75	7.94	6.60	—	2.44	6.50	3.56	0.56	0.063	0.72	3.02	—	0.63	0.469
2400	2.375	5.25	10.44	3.63	2.69	6.69	5.38	8.69	7.79	7.51	2.75	7.25	4.13	0.63	0.063	0.72	3.58	—	0.66	0.469
2600	2.625	5.59	11.13	4.03	2.97	7.38	5.94	9.69	7.91	7.63	2.94	8.06	4.50	0.63	0.063	0.81	3.71	—	0.72	0.531
(F) 3200	3.250	6.25	12.44	4.75	3.56	8.63	7.13	11.19	9.25	10.25	3.25	9.50	5.38	0.75	0.063	0.84	4.55	7.13	0.75	0.531
(F) 3800	3.750	7.00	13.94	5.41	4.03	9.75	8.06	12.63	9.75	10.75	3.94	10.81	6.13	0.81	0.063	0.91	5.05	7.81	0.84	0.594
(F) 4500	4.500	7.94	15.81	6.13	4.56	11.13	9.13	14.38	11.56	12.56	5.31	12.25	7.97	0.88	0.063	1.06	5.90	8.88	1.00	0.656
(F) 5200	5.167	8.63	17.19	7.13	5.25	12.75	10.50	16.63	12.22	13.22	5.84	14.25	8.75	0.94	0.063	1.19	6.55	9.63	1.13	0.781

ASSEMBLIES

STYLE MR*

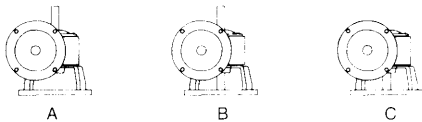

SUFFIX

A

B

C

STYLE MRA*

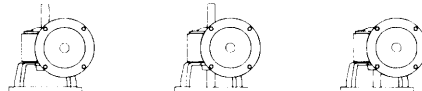

INPUT SHAFT

SIZE	T	V	V ₁	KEYWAY
1300	0.4990	2.41	—	.13 x .06
1800	0.4990	2.29	—	.13 x .06
2100	0.6240	2.29	—	.19 x .09
2400	0.7490	2.53	2.90	.19 x .09
2600	0.7490	2.29	2.93	.19 x .09
(F) 3200	0.8740	2.37	3.37	.19 x .09
(F) 3800	0.9990	2.25	3.25	.25 x .13
(F) 4500	1.1240	2.56	3.56	.25 x .13
(F) 5200	1.2490	2.22	3.22	.25 x .13

OUTPUT SHAFT

M	N	O	KEYWAY
1.75	0.6240	1.50	.19 x .09
2.56	0.7490	2.34	.19 x .09
2.53	0.8740	2.34	.19 x .09
2.84	0.9990	2.63	.25 x .13
2.79	1.1240	2.53	.25 x .13
3.17	1.2490	2.97	.25 x .13
3.23	1.4990	3.25	.38 x .19
3.82	1.6240	3.88	.38 x .19
4.25	1.7490	4.25	.38 x .19

For ratings see page 12, 13 • For ordering information see page 16
For couplings see page 61 • Dimensions shown are for reference only
Certified prints available upon request • For mounting positions see
page 68 • Service and maintenance see page 69

MOTOR FLANGE DIMENSIONS

MOTOR FRAME	AJ	AK	BD	BE	BE ₁	BF	BORE	KEYWAY
C = 56C	5.88	4.50	6.50	0.41	—	0.406	—	—
L = 143TC = 145TC	5.88	4.50	6.50	0.41	—	0.406	—	—

MOTOR FRAME	AJ	AK	BD	BE	BE ₁	BF	BORE	KEYWAY
G = 182TC = 184TC	7.25	8.50	9.00	—	0.22	0.531	—	—
W = 213TC = 215TC	7.25	8.50	8.91	—	0.38	0.531	1.3760	.31 x .15

H₁ AND V₁ FOR 182TC, 184TC ONLY

**LOW RECTANGULAR BASE
COUPLED C-FACE INPUT
VERTICAL SHAFT**

STYLE MN*-MNA*

DIMENSIONS

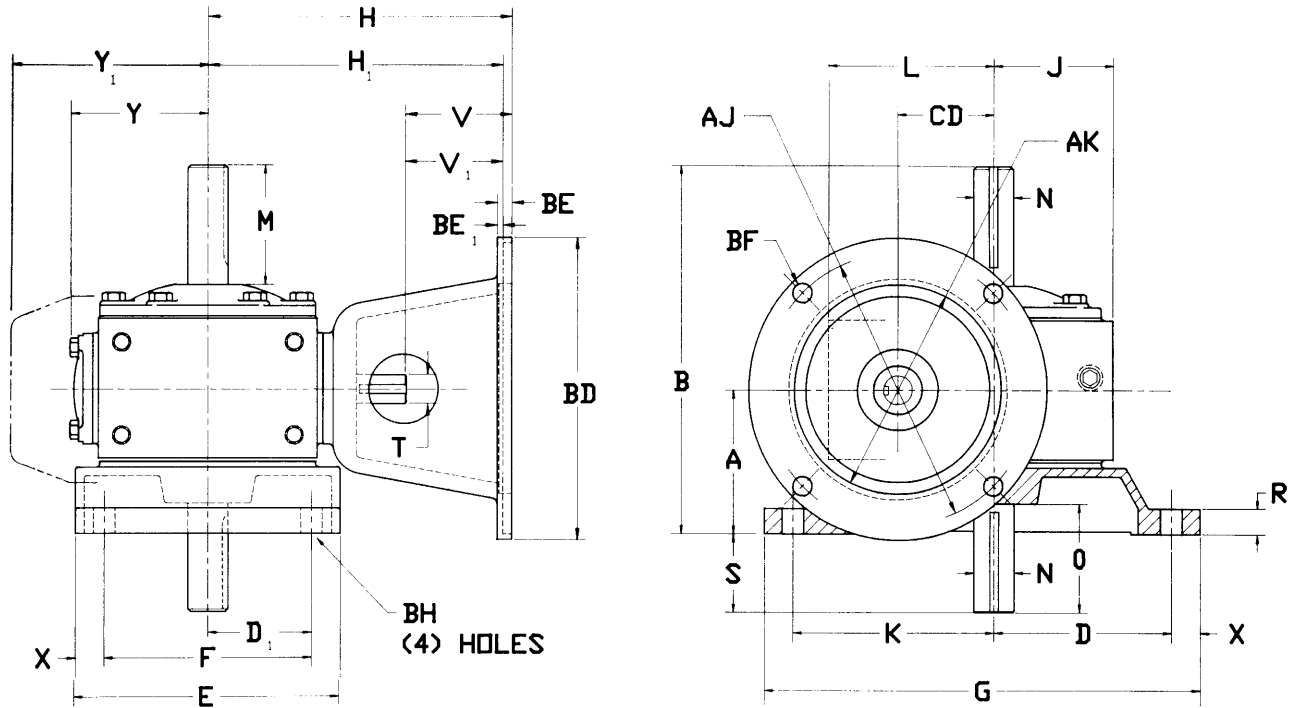

SIZE	C.D.	A	B	D	D ₁	E	F	G	H	H ₁	J	K	L	R	S	X	Y	Y ₁	BH
1300	1.333	2.31	5.81	2.81	1.50	3.88	3.00	6.88	5.91	—	1.56	3.19	2.53	0.38	1.19	0.44	2.27	—	0.344
1800	1.750	3.00	7.32	3.50	2.00	5.25	4.00	8.69	6.29	—	1.88	3.94	3.13	0.50	1.31	0.63	2.65	—	0.406
2100	2.063	3.13	7.94	3.88	2.25	5.75	4.50	9.50	6.60	—	2.44	4.38	3.56	0.56	1.69	0.63	3.02	—	0.469
2400	2.375	3.38	8.57	4.13	2.50	6.38	5.00	10.25	7.78	7.51	2.75	4.75	4.13	0.63	1.81	0.69	3.58	—	0.469
2600	2.625	3.63	9.15	4.63	2.88	7.25	5.75	11.50	7.91	7.63	2.94	5.38	4.50	0.69	1.91	0.75	3.71	—	0.531
(F) 3200	3.250	4.69	10.88	5.25	3.63	8.75	7.25	13.13	9.25	10.25	3.25	6.38	5.38	0.75	1.50	0.75	4.55	7.13	0.531
(F) 3800	3.750	5.25	12.19	5.88	4.13	10.00	8.25	14.88	9.75	10.75	3.94	7.25	6.13	0.81	1.69	0.88	5.05	7.81	0.594
(F) 4500	4.500	5.63	13.50	6.88	4.75	11.50	9.50	17.13	11.56	12.56	5.31	8.25	7.97	0.88	2.25	1.00	5.90	8.88	0.656
(F) 5200	5.167	6.38	14.94	7.63	5.38	13.00	10.75	19.13	12.22	13.22	5.84	9.25	8.75	0.94	2.19	1.13	6.55	9.63	0.781

INPUT SHAFT

SIZE	T	V	V ₁	KEYWAY
1300	0.4990	2.41	—	.13 x .06
1800	0.4990	2.29	—	.13 x .06
2100	0.6240	2.29	—	.19 x .09
2400	0.7490	2.53	2.90	.19 x .09
2600	0.7490	2.29	2.93	.19 x .09
(F) 3200	0.8740	2.37	3.37	.19 X .09
(F) 3800	0.9990	2.25	3.25	.25 X .13
(F) 4500	1.1240	2.56	3.56	.25 X .13
(F) 5200	1.2490	2.22	3.22	.25 X .13

OUTPUT SHAFT

M	N	O	KEYWAY
1.75	0.6240	1.50	.19 x .09
2.56	0.7490	2.31	.19 x .09
2.53	0.8740	2.34	.19 x .09
2.81	0.9990	2.63	.25 x .13
2.79	1.1240	2.53	.25 x .13
3.17	1.2490	2.97	.25 X .13
3.23	1.4990	3.25	.38 X .19
3.82	1.6240	3.88	.38 X .19
4.25	1.7490	4.25	.38 X .19

ASSEMBLIES

STYLE MN*

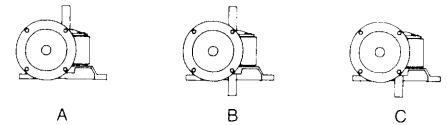

SUFFIX

STYLE MNA*

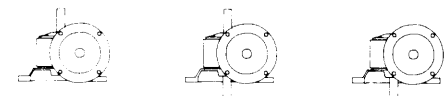

For ratings see page 12, 13 • For ordering information see page 16
For couplings see page 61 • Dimensions shown are for reference only
Certified prints available upon request • For mounting positions see page 68 • Service and maintenance see page 69

MOTOR FLANGE DIMENSIONS

MOTOR FRAME	AJ	AK	BD	BE	BE ₁	BF	BORE	KEYWAY
C = 56C	5.88	4.50	6.50	0.41	—	0.406	—	—
L = 143TC = 145TC	5.88	4.50	6.50	0.41	—	0.406	—	—

MOTOR FRAME	AJ	AK	BD	BE	BE ₁	BF	BORE	KEYWAY
G = 182TC = 184TC	7.25	8.50	9.00	—	0.22	0.531	—	—
W = 213TC = 215TC	7.25	8.50	8.91	—	0.38	0.531	1.3760	.31 x .15

STYLE SD

PARALLEL SHAFTS DOUBLE REDUCTION WORM GEAR REDUCER

DIMENSIONS

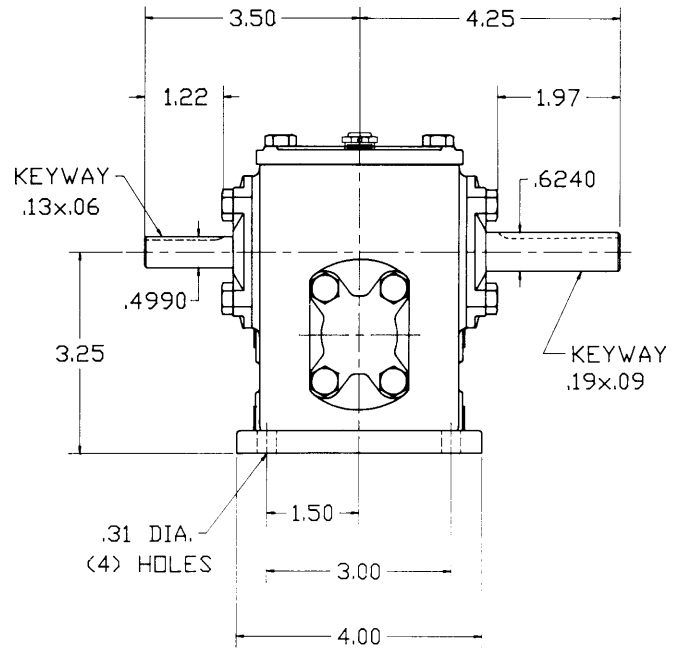
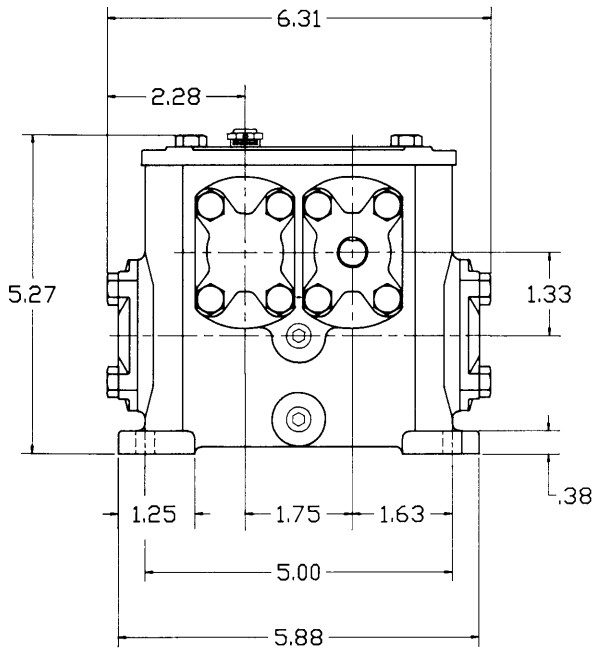

ASSEMBLIES

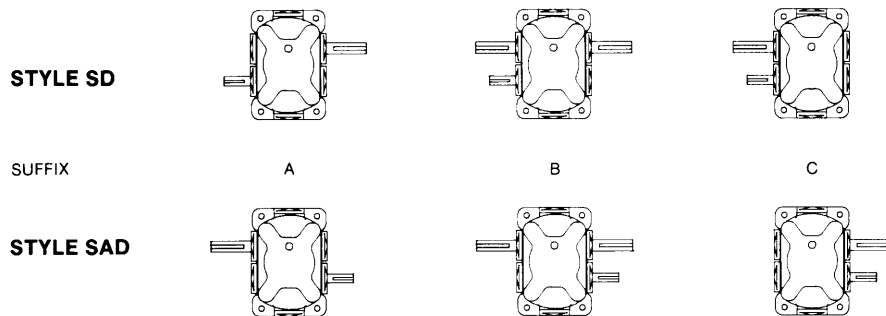

For ratings see page 14, 15 • For ordering information see page 16
 Dimensions shown are for reference only • Certified prints available upon request
 Service and maintenance see page 69

**PARALLEL SHAFTS
 QUILLED C-FACE INPUT
 DOUBLE REDUCTION
 WORM GEAR REDUCER**

STYLE SCD

DIMENSIONS

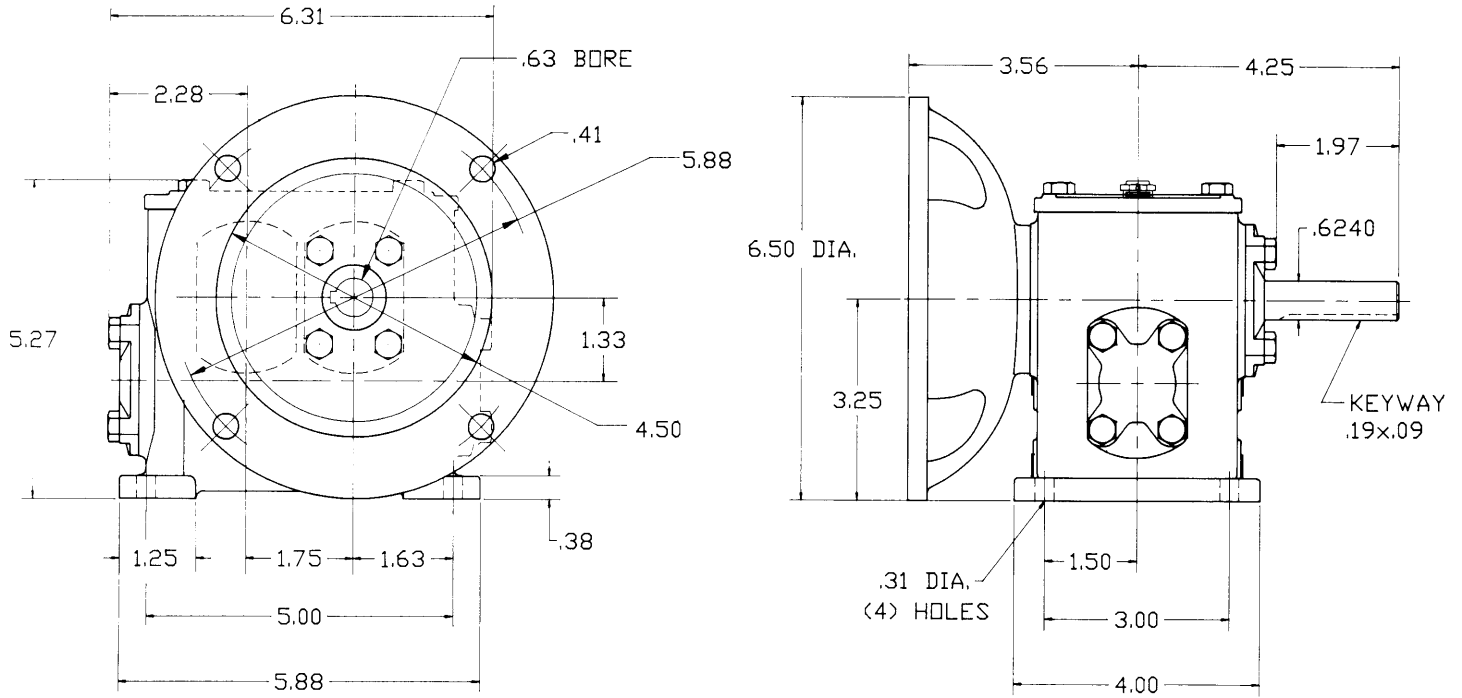

ASSEMBLIES

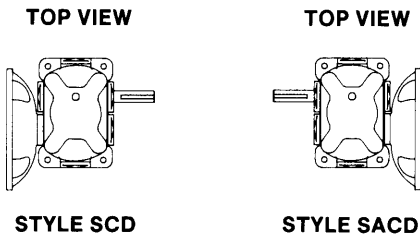

SUFFIX A ONLY

For ratings see page 14, 15 • For ordering information see page 16
 Dimensions shown are for reference only • Certified prints available upon request
 Service and maintenance see page 69

STYLE TD-TAD

SECONDARY WORM TOP
CAST ON BASE
DOUBLE REDUCTION

DIMENSIONS

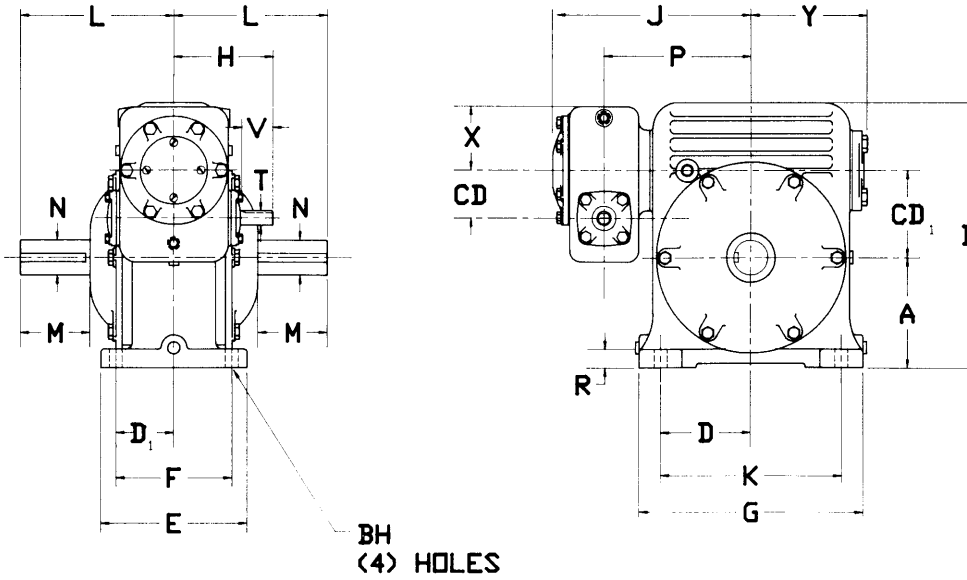

SIZE	CD	CD ₁	A	B	D	D ₁	E	F	G	H	J	K	L	P	R	X	Y	BH
130000	1.333	1.333	1.88	4.63	1.63	1.63	4.00	3.25	4.00	3.50	5.55	3.25	3.25	3.50	.38	1.60	2.51	.281
180000	1.333	1.750	2.25	5.63	2.00	1.75	4.50	3.50	5.00	3.50	5.93	4.00	3.50	3.87	.38	1.60	2.88	.406
210000	1.750	2.063	3.13	7.06	2.38	2.06	5.13	4.13	5.75	4.00	6.37	4.75	4.25	4.31	.50	1.88	3.16	.406
240000	1.750	2.375	3.50	8.00	2.75	2.06	5.13	4.13	6.50	4.00	6.87	5.50	4.06	4.81	.56	1.88	3.57	.406
260000	1.750	2.625	3.63	8.63	2.94	2.38	5.75	4.75	7.00	4.00	6.99	5.88	5.00	4.94	.63	1.88	3.69	.469
320000	2.063	3.250	4.38	10.38	3.75	2.50	6.25	5.00	8.88	4.31	8.18	7.50	5.44	5.91	.88	2.75	4.55	.531
380000	2.063	3.750	4.75	11.44	3.94	2.53	6.38	5.06	9.75	4.31	8.68	7.88	6.69	6.41	.81	2.75	5.05	.531
450000	2.625	4.500	5.50	13.56	4.53	2.75	7.00	5.50	10.75	5.63	9.90	9.06	7.25	7.38	.88	3.22	5.90	.563
520000	2.625	5.167	6.00	14.75	5.13	2.95	7.63	5.91	12.31	5.63	10.55	10.25	7.81	8.03	.94	3.22	6.55	.688

ASSEMBLIES

STYLE TD

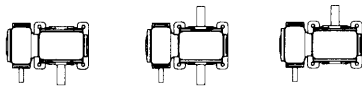

SUFFIX

A

B

C

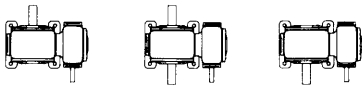

STYLE TAD

INPUT SHAFT

SIZE	T	V	KEYWAY
130000	.4990	1.38	.13 × .06
180000	.4990	1.38	.13 × .06
210000	.4990	1.50	.13 × .06
240000	.4990	1.50	.13 × .06
260000	.4990	1.50	.13 × .06
320000	.6240	1.41	.19 × .09
380000	.6240	1.41	.19 × .09
450000	.7490	1.94	.19 × .09
520000	.7490	1.94	.19 × .09

OUTPUT SHAFT

M	N	KEYWAY
1.50	.6240	.19 × .09
1.75	.7490	.19 × .09
1.97	.8740	.19 × .09
1.72	.9990	.25 × .13
2.25	1.1240	.25 × .13
2.44	1.2490	.25 × .13
3.00	1.4990	.38 × .19
3.19	1.6240	.38 × .19
3.53	1.7490	.38 × .19

For ratings see page 14, 15 • For ordering information see page 16 • For motor adapters and couplings see page 61
Dimensions shown are for reference only • Certified prints available upon request • For mounting positions see page 68
Service and maintenance see page 69

**CIRCULAR BASE
VERTICAL SHAFT
DOUBLE REDUCTION**

STYLE VD-VAD

DIMENSIONS

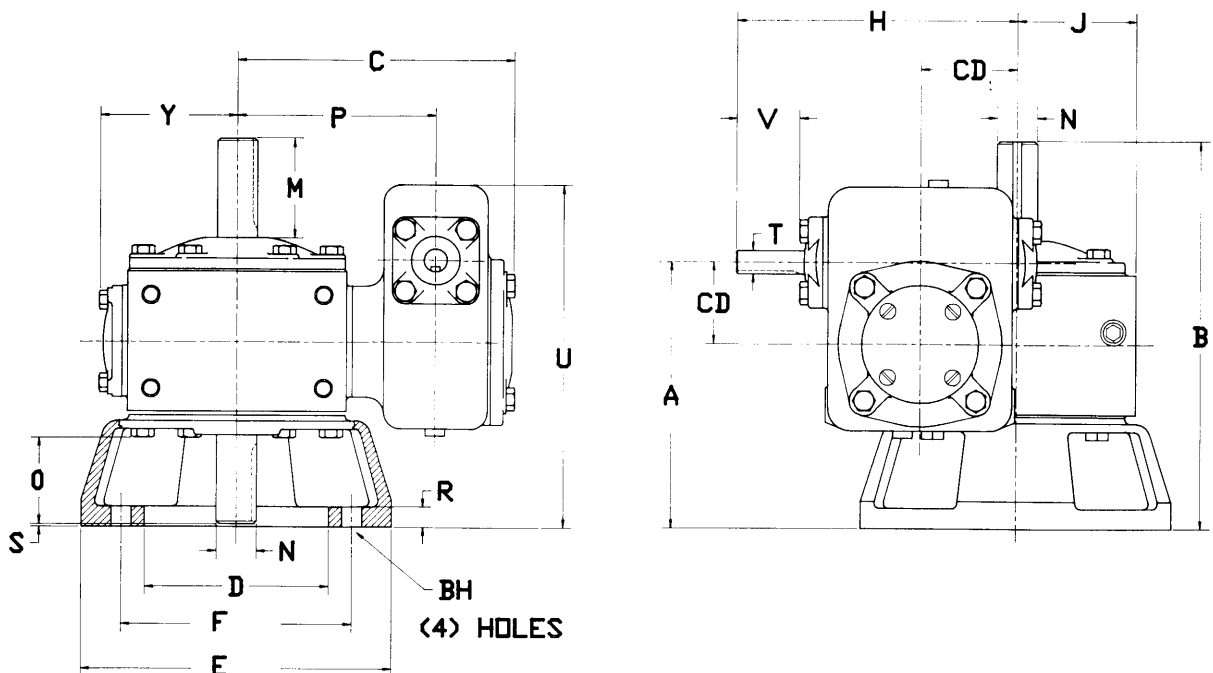

SIZE	CD	CD ₁	A	B	C	D	E	F	H	J	P	R	S	U	Y	BH
130000	1.333	1.333	4.33	6.31	5.55	3.38	4.88	4.00	4.83	1.56	3.50	.28	.063	5.74	2.51	.281
180000	1.333	1.750	4.58	6.75	5.93	3.63	5.63	4.13	5.25	1.88	3.87	.31	.063	5.99	2.88	.281
210000	1.750	2.063	5.75	8.38	6.37	4.00	6.75	5.00	6.06	2.44	4.31	.44	.063	7.41	3.16	.406
240000	1.750	2.375	6.13	8.69	6.87	4.63	7.44	5.63	6.38	2.75	4.81	.47	.063	7.79	3.57	.406
260000	1.750	2.625	6.38	9.72	6.99	5.50	7.69	6.25	6.63	2.94	4.94	.50	.063	8.04	3.69	.406
320000	2.063	3.250	7.06	10.44	8.18	6.00	9.38	7.00	7.56	3.25	5.91	.56	.063	8.97	4.55	.531
380000	2.063	3.750	7.44	11.31	8.68	6.50	10.50	7.75	8.06	3.94	6.41	.63	.063	9.34	5.05	.531
450000	2.625	4.500	8.63	12.91	9.90	7.50	12.00	9.00	10.13	5.31	7.38	.63	.063	11.00	5.90	.531
520000	2.625	5.167	9.13	13.78	10.55	8.50	13.81	10.25	10.80	5.84	8.04	.69	.063	11.50	6.55	.531

INPUT SHAFT

SIZE	T	V	KEYWAY
130000	.4990	1.38	.13 × .06
180000	.4990	1.38	.13 × .06
210000	.4990	1.50	.13 × .06
240000	.4990	1.50	.13 × .06
260000	.4990	1.50	.13 × .06
320000	.6240	1.41	.19 × .09
380000	.6240	1.41	.19 × .09
450000	.7490	1.94	.19 × .09
520000	.7490	1.94	.19 × .09

OUTPUT SHAFT

M	N	O	KEYWAY
1.50	.6240	1.38	.19 × .09
1.75	.7490	1.56	.19 × .09
2.09	.8740	1.94	.19 × .09
1.96	.9990	1.66	.25 × .13
2.34	1.1240	2.13	.25 × .13
2.44	1.2490	2.22	.25 × .13
2.23	1.4990	2.25	.38 × .19
2.84	1.6240	2.84	.38 × .19
2.96	1.7490	2.97	.38 × .19

ASSEMBLIES

STYLE VD

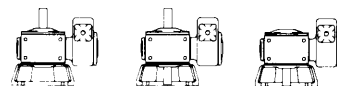

SUFFIX

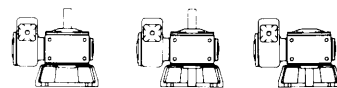

STYLE VAD

For ratings see page 14, 15 • For ordering information see page 16 • For motor adapters and couplings see page 61
Dimensions shown are for reference only • Certified prints available upon request • For mounting positions see page 68
Service and maintenance see page 69

STYLE RD-RAD

HIGH RECTANGULAR BASE
VERTICAL SHAFT
DOUBLE REDUCTION

DIMENSIONS

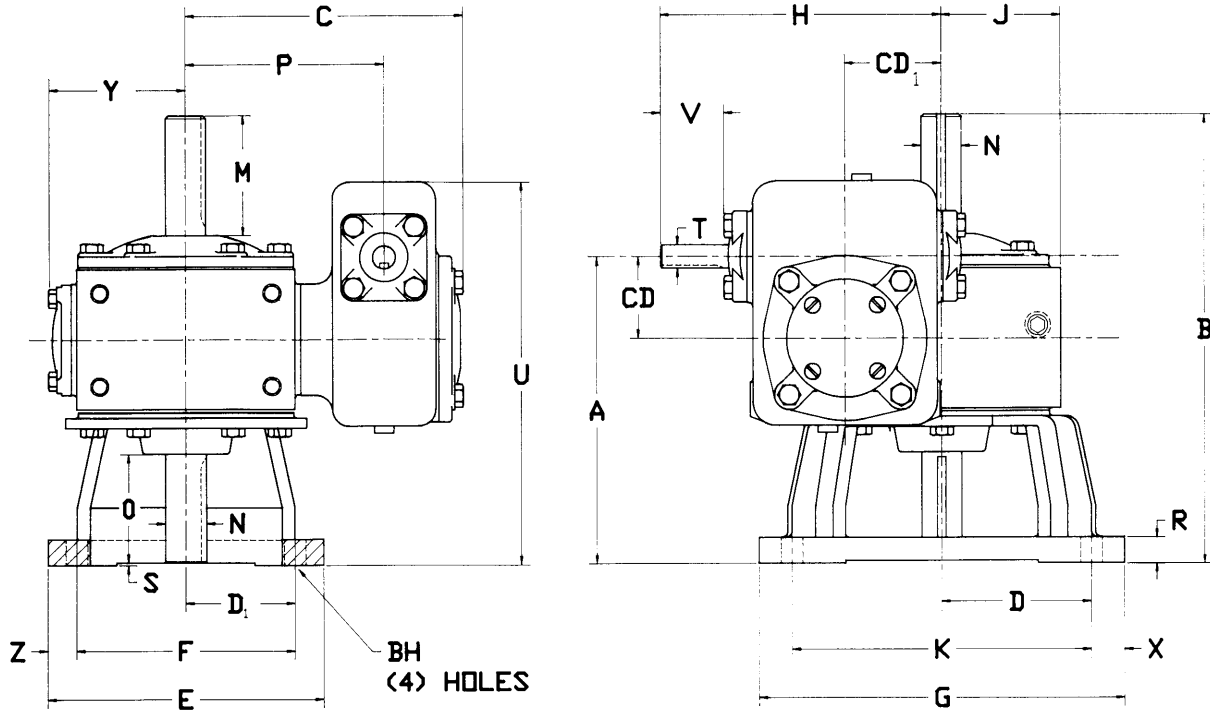

SIZE	CD	CD ₁	A	B	C	D	D ₁	E	F	G	H	J	K	P	R	S	U	X	Y	Z	BH
130000	1.333	1.333	4.89	7.06	5.55	2.25	1.69	4.25	3.38	5.50	4.83	1.56	4.50	3.50	.44	.063	6.30	.50	2.51	.44	.344
180000	1.333	1.750	5.71	8.69	5.93	2.97	2.16	5.50	4.31	7.19	5.25	1.88	5.94	3.87	.50	.063	7.12	.63	2.88	.59	.406
210000	1.750	2.063	6.63	9.69	6.37	3.25	2.38	6.00	4.75	7.94	6.06	2.44	6.50	4.31	.56	.063	8.29	.72	3.16	.63	.469
240000	1.750	2.375	7.00	10.44	6.87	3.63	2.69	6.69	5.38	8.69	6.38	2.75	7.25	4.81	.63	.063	8.66	.72	3.57	.66	.469
260000	1.750	2.625	7.34	11.13	6.99	4.03	2.97	7.38	5.94	9.69	6.63	2.94	8.06	4.94	.63	.063	9.00	.81	3.69	.72	.531
320000	2.063	3.250	8.31	12.44	8.18	4.75	3.56	8.63	7.13	11.19	7.56	3.25	9.50	5.91	.75	.063	10.22	.84	4.55	.75	.531
380000	2.063	3.750	9.06	13.94	8.68	5.41	4.03	9.75	8.06	12.63	8.06	3.94	10.81	6.41	.81	.063	10.97	.91	5.05	.84	.594
450000	2.625	4.500	10.57	15.81	9.90	6.13	4.56	11.13	9.13	14.38	10.13	5.31	12.25	7.38	.88	.063	12.94	1.06	5.90	1.00	.656
520000	2.625	5.167	11.25	17.19	10.55	7.13	5.25	12.75	10.50	16.63	10.80	5.84	14.25	8.04	.94	.063	13.63	1.19	6.55	1.13	.781

ASSEMBLIES

STYLE RD

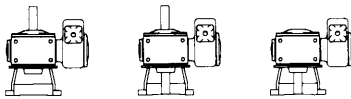

SUFFIX

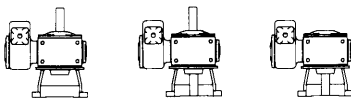

STYLE RAD

INPUT SHAFT

SIZE	T	V	KEYWAY
130000	.4990	1.38	.13 × .06
180000	.4990	1.38	.13 × .06
210000	.4990	1.50	.13 × .06
240000	.4990	1.50	.13 × .06
260000	.4990	1.50	.13 × .06
320000	.6240	1.41	.19 × .09
380000	.6240	1.41	.19 × .09
450000	.7490	1.94	.19 × .09
520000	.7490	1.94	.19 × .09

OUTPUT SHAFT

M	N	O	KEYWAY
1.75	.6240	1.50	.19 × .09
2.56	.7490	2.34	.19 × .09
2.53	.8740	2.34	.19 × .09
2.84	.9990	2.63	.25 × .13
2.79	1.1240	2.53	.25 × .13
3.17	1.2490	2.97	.25 × .13
3.23	1.4990	3.25	.38 × .19
3.82	1.6240	3.88	.38 × .19
4.25	1.7490	4.25	.38 × .19

For ratings see page 14, 15 • For ordering information see page 16 • For motor adapters and couplings see page 61
Dimensions shown are for reference only • Certified prints available upon request • For mounting positions see page 68
Service and maintenance see page 69

**LOW RECTANGULAR BASE
VERTICAL SHAFT
DOUBLE REDUCTION**

STYLE ND-NAD

DIMENSIONS

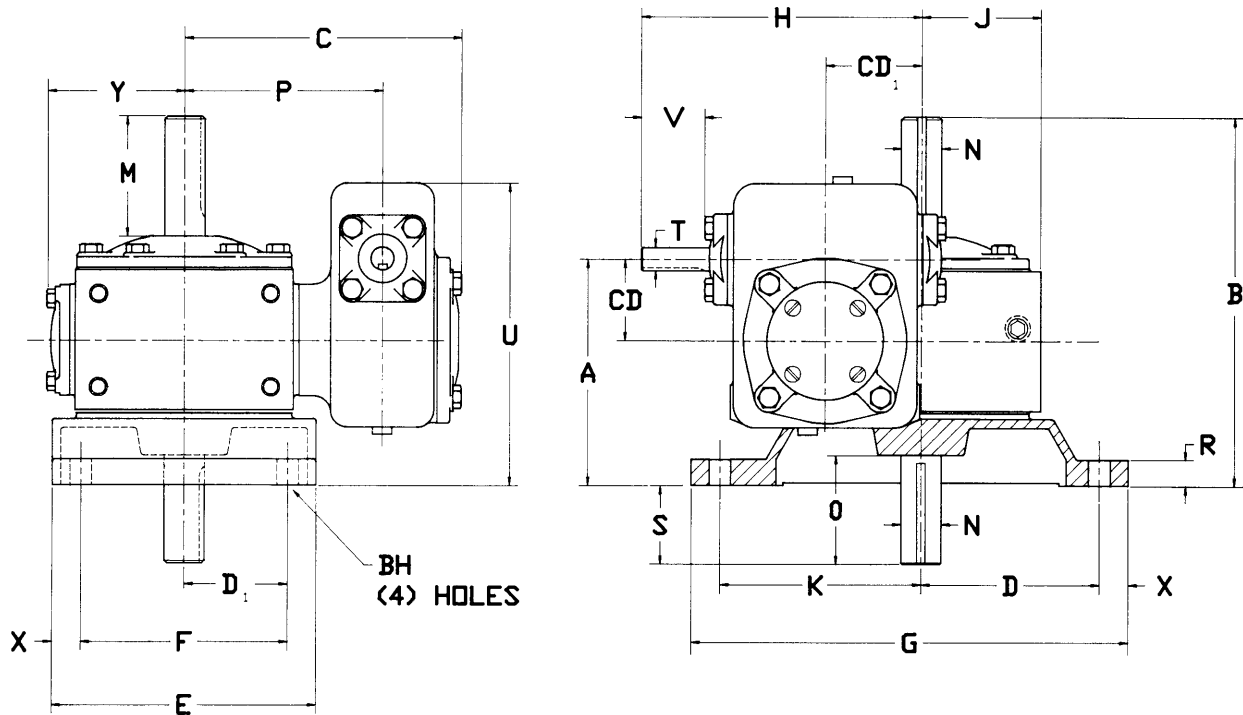

SIZE	CD	CD ₁	A	B	C	D	D ₁	E	F	G	H	J	K	P	R	S	U	X	Y	BH
130000	1.333	1.333	3.64	5.81	5.55	2.81	1.50	3.88	3.00	6.88	4.83	1.56	3.19	3.50	.38	1.19	5.05	.44	2.51	.344
180000	1.333	1.750	4.33	7.31	5.93	3.50	2.00	5.25	4.00	8.69	5.25	1.88	3.94	3.87	.50	1.31	5.73	.63	2.88	.406
210000	1.750	2.063	4.88	7.94	6.37	3.88	2.25	5.75	4.50	9.50	6.06	2.44	4.38	4.31	.56	1.69	6.53	.63	3.16	.469
240000	1.750	2.375	5.13	8.56	6.87	4.13	2.50	6.38	5.00	10.25	6.38	2.75	4.75	4.81	.63	1.81	6.78	.69	3.57	.469
260000	1.750	2.625	5.38	9.15	6.99	4.63	2.88	7.25	5.75	11.50	6.63	2.94	5.38	4.94	.69	1.91	7.03	.75	3.69	.531
320000	2.063	3.250	6.75	10.88	8.18	5.25	3.63	8.75	7.25	13.13	7.56	3.25	6.38	5.91	.75	1.50	8.65	.75	4.55	.531
380000	2.063	3.750	7.31	12.19	8.68	5.88	4.13	10.00	8.25	14.88	8.06	3.94	7.25	6.41	.81	1.69	9.21	.88	5.05	.594
450000	2.625	4.500	8.25	13.50	9.90	6.88	4.75	11.50	9.50	17.13	10.13	5.31	8.25	7.38	.88	2.25	10.62	1.00	5.90	.656
520000	2.625	5.167	9.00	14.94	10.55	7.63	5.38	13.00	10.75	19.13	10.80	5.84	9.25	8.04	.94	2.19	11.37	1.13	6.55	.781

INPUT SHAFT

SIZE	T	V	KEYWAY
130000	.4990	1.38	.13 × .06
180000	.4990	1.38	.13 × .06
210000	.4990	1.50	.13 × .06
240000	.4990	1.50	.13 × .06
260000	.4990	1.50	.13 × .06
320000	.6240	1.41	.19 × .09
380000	.6240	1.41	.19 × .09
450000	.7490	1.94	.19 × .09
520000	.7490	1.94	.19 × .09

OUTPUT SHAFT

M	N	O	KEYWAY
1.75	.6240	1.50	.19 × .09
2.56	.7490	2.31	.19 × .09
2.53	.8740	2.34	.19 × .09
2.81	.9990	2.63	.25 × .13
2.79	1.1240	2.53	.25 × .13
3.17	1.2490	2.97	.25 × .13
3.23	1.4990	3.25	.38 × .19
3.82	1.6240	3.88	.38 × .19
4.25	1.7490	4.25	.38 × .19

ASSEMBLIES

STYLE ND

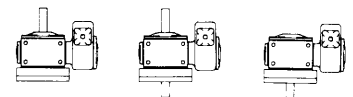

SUFFIX

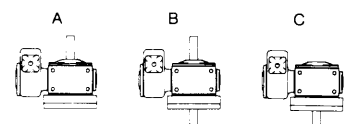

STYLE NAD

For ratings see page 14, 15 • For ordering information see page 16 • For motor adapters and couplings see page 61
 Dimensions shown are for reference only • Certified prints available upon request • For mounting positions see page 68
 Service and maintenance see page 69



STYLE T*D-TA*D

SECONDARY WORM TOP
QUILLED C-FACE INPUT
CAST ON BASE
DOUBLE REDUCTION

DIMENSIONS

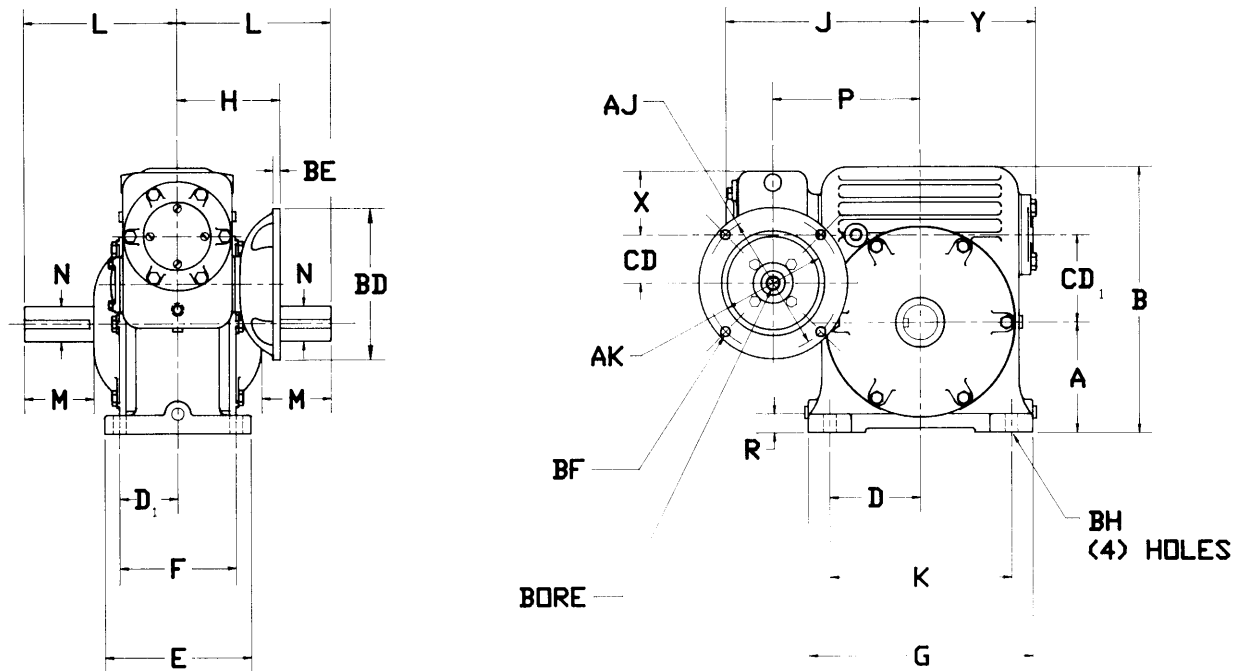

SIZE	C.D.	CD ₁	A	B	D	D ₁	E	F	G	H	J	K	L	P	R	X	Y	BH
**130000	1.333	1.333	1.88	4.63	1.63	1.63	4.00	3.25	4.00	3.73	5.55	3.25	3.25	3.50	.38	2.70	2.51	.281
**180000	1.333	1.750	2.25	5.63	2.00	1.75	4.50	3.50	5.00	3.73	5.93	4.00	3.50	3.87	.38	2.70	2.88	.406
210000	1.750	2.063	3.13	7.06	2.38	2.06	5.13	4.13	5.75	4.11	6.37	4.75	4.25	4.31	.50	1.88	3.16	.406
240000	1.750	2.375	3.50	8.00	2.75	2.06	5.13	4.13	6.50	4.11	6.87	5.50	4.06	4.81	.56	1.88	3.57	.406
260000	1.750	2.625	3.63	8.63	2.94	2.38	5.75	4.75	7.00	4.11	6.99	5.88	5.00	4.94	.63	1.88	3.69	.469
320000	2.063	3.250	4.38	10.38	3.75	2.50	6.25	5.00	8.88	4.48	8.18	7.50	5.44	5.91	.88	2.75	4.55	.531
380000	2.063	3.750	4.75	11.44	3.94	2.53	6.38	5.06	9.75	4.48	8.68	7.88	6.69	6.41	.81	2.75	5.05	.531
450000	2.625	4.500	5.50	13.56	4.53	2.75	7.00	5.50	10.75	5.10	9.90	9.06	7.25	7.38	.88	3.22	5.90	.563
520000	2.625	5.167	6.00	14.75	5.13	2.95	7.63	5.91	12.31	5.10	10.55	10.25	7.81	8.04	.94	3.22	6.55	.688

*MOTOR FLANGE DIMENSIONS

MOTOR FRAME	AJ	AK	BD	BE	BF	BORE	KEYWAY
C = 56C	5.88	4.50	6.50	.31	422	6260	.19 X .09
L = ^{143TC} / _{145TC}	5.88	4.50	6.50	.31	422	8760	.19 X .09

OUTPUT SHAFT

SIZE	M	N	KEYWAY
130000	1.50	.6240	.19 X .09
180000	1.75	.7490	.19 X .09
210000	1.97	.8740	.19 X .09
240000	1.72	.9990	.25 X .13
260000	2.25	1.1240	.25 X .13
320000	2.44	1.2490	.25 X .13
380000	3.00	1.4990	.38 X .19
450000	3.19	1.6240	.38 X .19
520000	3.53	1.7490	.38 X .19

ASSEMBLIES

STYLE T*D

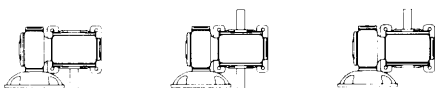

SUFFIX A

B

C

STYLE TA*D

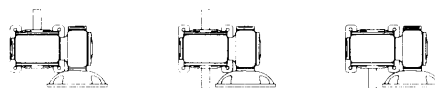

A

B

C

**Primary input top. Motor adapter center line to base = A + CD₁ + CD

For ratings see page 14, 15 • For ordering information see page 16
Dimensions shown are for reference only • Certified prints available upon request • For mounting positions see page 68
Service and maintenance see page 69

**CIRCULAR BASE
QUILLED C-FACE INPUT
VERTICAL SHAFT
DOUBLE REDUCTION**

STYLE V*D-VA*D

DIMENSIONS

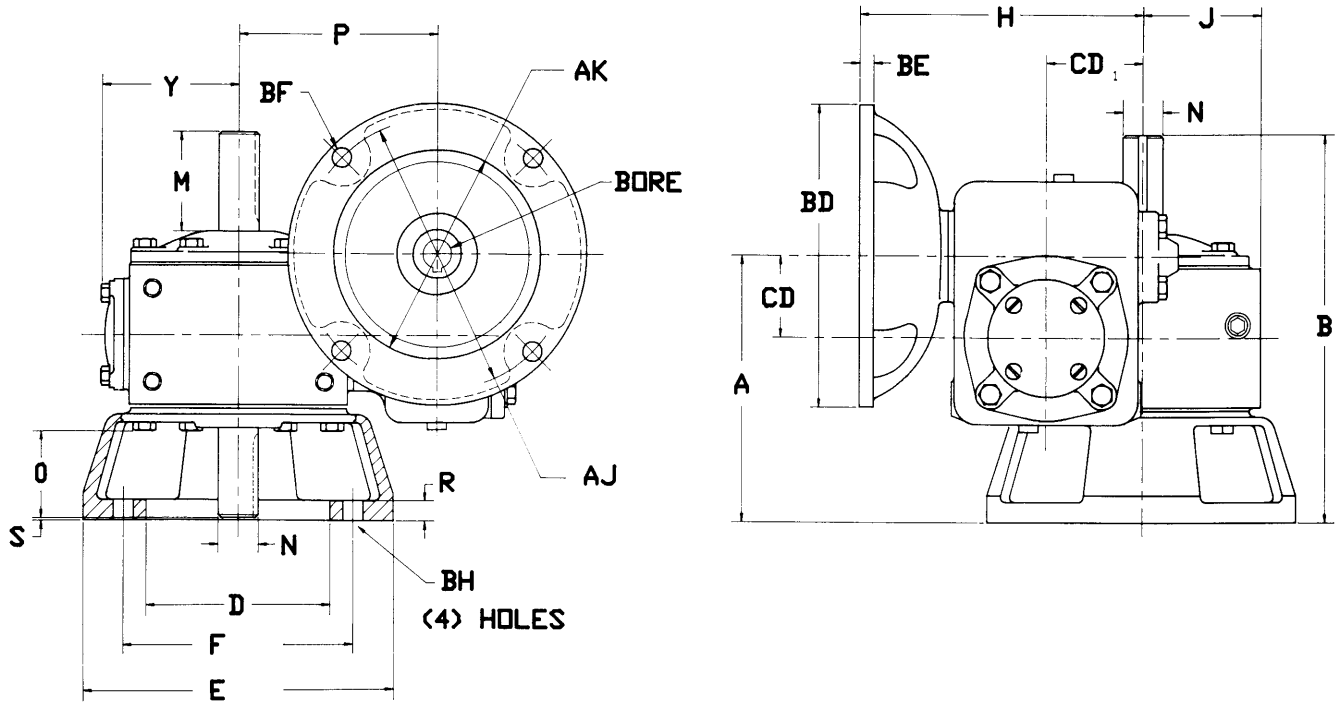

SIZE	CD	CD ₁	A	B	D	E	F	H	J	P	R	S	Y	BH
130000	1.333	1.333	4.33	6.31	3.38	4.88	4.00	5.06	1.56	3.50	.28	.063	2.51	.281
180000	1.333	1.750	4.58	6.75	3.63	5.63	4.13	5.48	1.88	3.87	.31	.063	2.88	.281
210000	1.750	2.063	5.75	8.38	4.00	6.75	5.00	6.17	2.44	4.31	.44	.063	3.16	.406
240000	1.750	2.375	6.13	8.69	4.63	7.44	5.63	6.48	2.75	4.81	.47	.063	3.57	.406
260000	1.750	2.625	6.38	9.72	5.50	7.69	6.25	6.73	2.94	4.94	.50	.063	3.69	.406
320000	2.063	3.250	7.06	10.44	6.00	9.38	7.00	7.73	3.25	5.91	.56	.063	4.55	.531
380000	2.063	3.750	7.44	11.31	6.50	10.50	7.75	8.23	3.94	6.41	.63	.063	5.05	.531
450000	2.625	4.500	8.63	12.91	7.50	12.00	9.00	9.61	5.31	7.38	.63	.063	5.90	.531
520000	2.625	5.167	9.13	13.78	8.50	13.81	10.25	10.27	5.84	8.04	.69	.063	6.55	.531

OUTPUT SHAFT

SIZE	M	N	O	KEYWAY
130000	1.50	.6240	1.38	.19 X .09
180000	1.75	.7490	1.56	.19 X .09
210000	2.09	.8740	1.94	.19 X .09
240000	1.96	.9990	1.66	.25 X .13
260000	2.34	1.1240	2.13	.25 X .13
320000	2.44	1.2490	2.22	.25 X .13
380000	2.23	1.4990	2.25	.38 X .19
450000	2.84	1.6240	2.84	.38 X .19
520000	2.96	1.7490	2.97	.38 X .19

*MOTOR FLANGE DIMENSIONS

MOTOR FRAME	AJ	AK	BD	BE	BF	BORE	KEYWAY
C = 56C	5.88	4.50	6.50	.31	.422	.6260	.19 X .09
L = ^{143TC} _{145TC}	5.88	4.50	6.50	.31	.422	.8760	.19 X .09

ASSEMBLIES

STYLE V*D

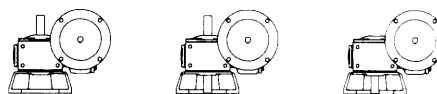

SUFFIX A

B

C

STYLE VA*D

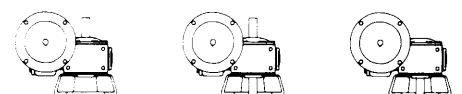

A

B

C

For ratings see page 14, 15 • For ordering information see page 16
Dimensions shown are for reference only • Certified prints available upon request • For mounting positions see page 68
Service and maintenance see page 69



PERFECTION GEAR

STYLE R*D-RA*D

HIGH RECTANGULAR BASE
 QUILLED C-FACE INPUT
 VERTICAL SHAFT
 DOUBLE REDUCTION

DIMENSIONS

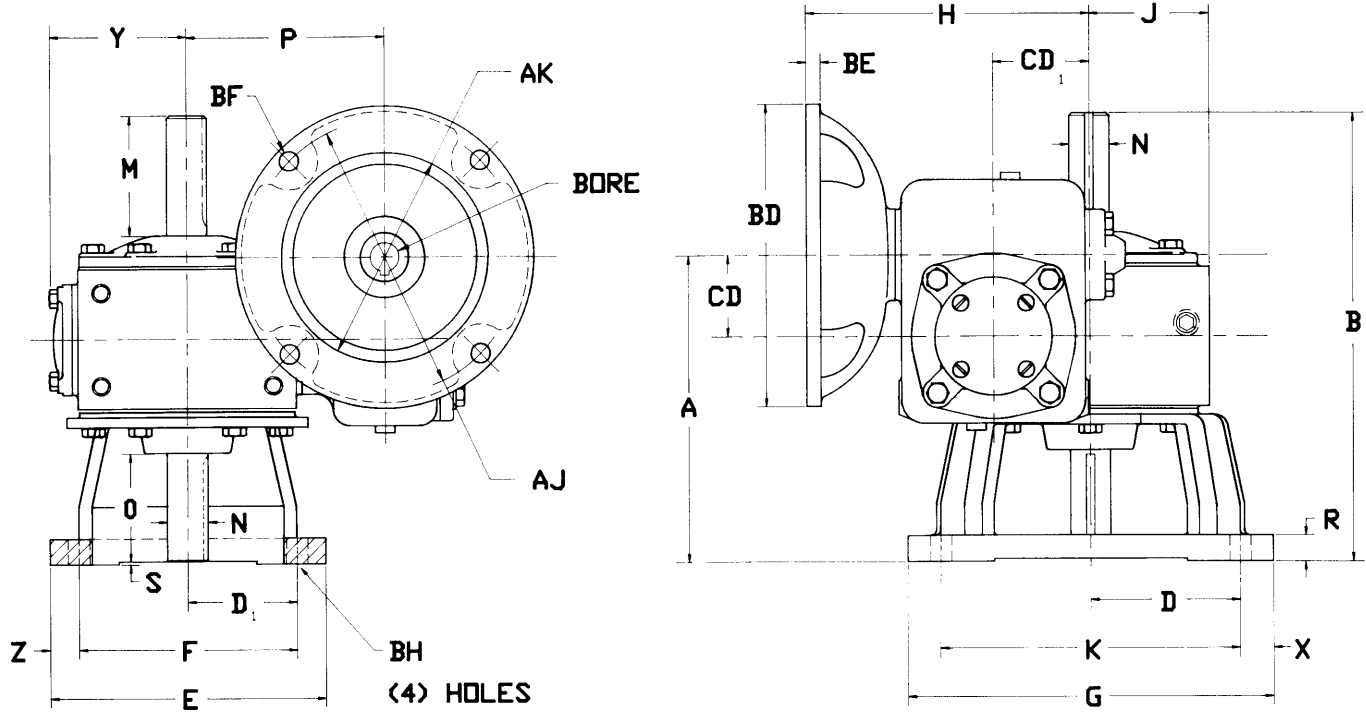

SIZE	CD	CD ₁	A	B	D	D ₁	E	F	G	H	J	K	P	R	S	X	Y	Z	BH
130000	1.333	1.333	4.89	7.06	2.25	1.69	4.25	3.38	5.50	5.06	1.56	4.50	3.50	.44	.063	.50	2.51	.44	.344
180000	1.333	1.750	5.71	8.69	2.97	2.16	5.50	4.31	7.19	5.48	1.88	5.94	3.87	.50	.063	.63	2.88	.59	.406
210000	1.750	2.063	6.63	9.69	3.25	2.38	6.00	4.75	7.94	6.17	2.44	6.50	4.31	.56	.063	.72	3.16	.63	.469
240000	1.750	2.375	7.00	10.44	3.63	2.69	6.69	5.38	8.69	6.48	2.75	7.25	4.81	.63	.063	.72	3.57	.66	.469
260000	1.750	2.625	7.34	11.13	4.03	2.97	7.38	5.94	9.65	6.73	2.94	8.06	4.94	.63	.063	.81	3.69	.72	.531
320000	2.063	3.250	8.31	12.44	4.75	3.56	8.63	7.13	11.19	7.73	3.25	9.50	5.91	.75	.063	.84	4.55	.75	.531
380000	2.063	3.750	9.06	13.94	5.41	4.03	9.75	8.06	12.63	8.23	3.94	10.81	6.41	.81	.063	.91	5.05	.84	.594
450000	2.625	4.500	10.56	15.81	6.13	4.56	11.13	9.13	14.38	9.61	5.31	12.25	7.38	.88	.063	1.06	5.90	1.00	.656
520000	2.625	5.167	11.25	17.19	7.13	5.25	12.75	10.50	16.63	10.27	5.84	14.25	8.04	.94	.063	1.19	6.55	1.13	.781

*MOTOR FLANGE DIMENSIONS

MOTOR FRAME	AJ	AK	BD	BE	BF	BORE	KEYWAY
C = 56C	5.88	4.50	6.50	31	.422	.6260	.19 X .09
L = ^{143TC} _{145TC}	5.88	4.50	6.50	31	.422	.8760	.19 X .09

OUTPUT SHAFT

SIZE	M	N	O	KEYWAY
130000	1.75	.6240	1.50	.19 X .09
180000	2.56	.7490	2.34	.19 X .09
210000	2.53	.8740	2.34	.19 X .09
240000	2.84	.9990	2.63	.25 X .13
260000	2.79	1.1240	2.53	.25 X .13
320000	3.17	1.2490	2.97	.25 X .13
380000	3.23	1.4990	3.25	.38 X .19
450000	3.82	1.6240	3.88	.38 X .19
520000	4.25	1.7490	4.25	.38 X .19

ASSEMBLIES

STYLE R*D

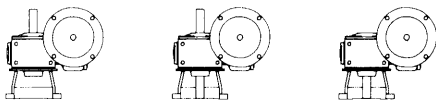

SUFFIX A

B

C

STYLE RA*D

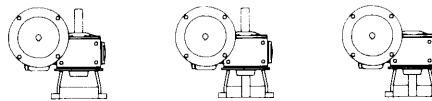

A

B

C

**LOW RECTANGULAR BASE
QUILLED C-FACE INPUT
VERTICAL SHAFT
DOUBLE REDUCTION**

STYLE N*D-NA*D

DIMENSIONS

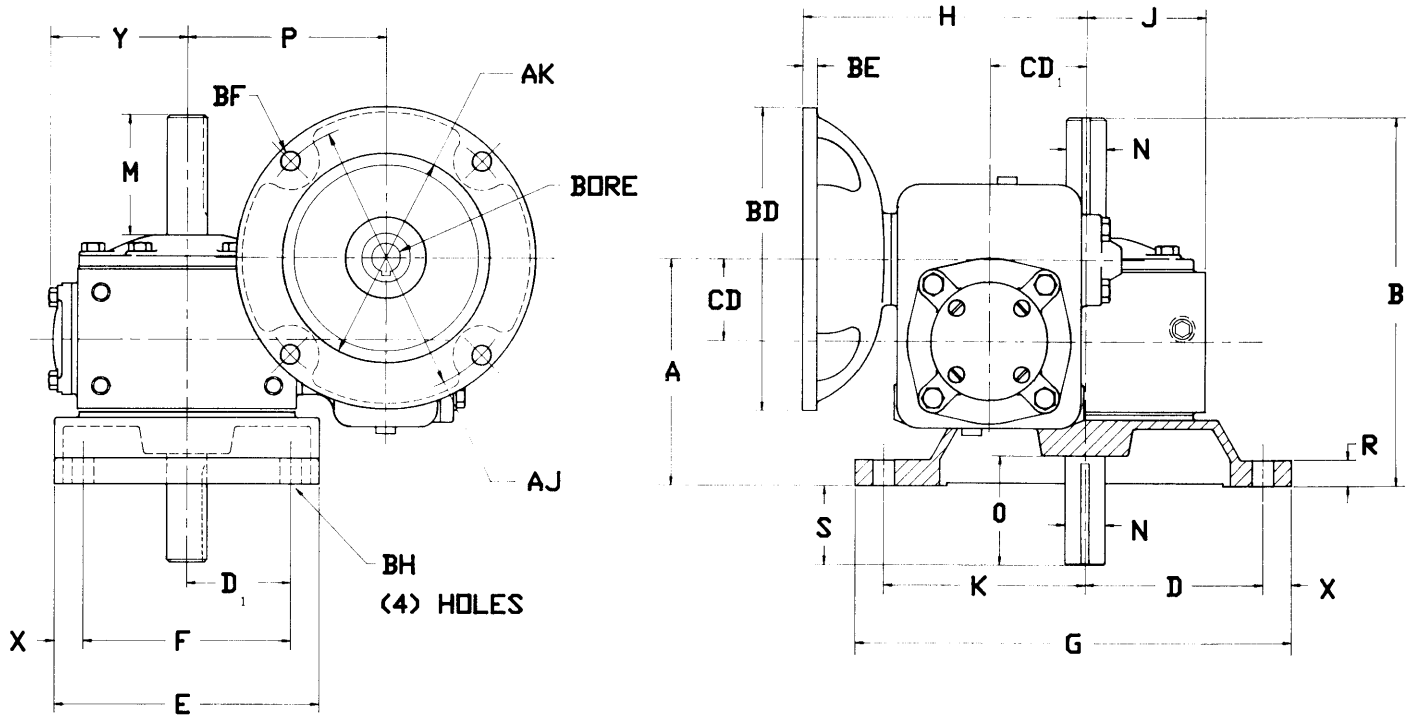

SIZE	CD	CD ₁	A	B	D	D ₁	E	F	G	H	J	K	P	R	S	X	Y	BH
130000	1.333	1.333	3.63	5.81	2.81	1.50	3.88	3.00	6.88	5.06	1.56	3.19	3.50	.38	1.19	.44	2.51	.344
180000	1.333	1.750	4.33	7.31	3.50	2.00	5.25	4.00	8.69	5.48	1.88	3.94	3.87	.50	1.31	.63	2.88	.406
210000	1.750	2.063	4.88	7.94	3.88	2.25	5.75	4.50	9.50	6.17	2.44	4.38	4.31	.56	1.69	.63	3.16	.469
240000	1.750	2.375	5.13	8.57	4.13	2.50	6.38	5.00	10.25	6.48	2.75	4.75	4.81	.63	1.81	.69	3.57	.469
260000	1.750	2.625	5.38	9.15	4.63	2.88	7.25	5.75	11.50	6.73	2.94	5.38	4.94	.69	1.91	.75	3.69	.531
320000	2.063	3.250	6.75	10.88	5.25	3.63	8.75	7.25	13.13	7.73	3.25	6.38	5.91	.75	1.50	.75	4.55	.531
380000	2.063	3.750	7.31	12.19	5.88	4.13	10.00	8.25	14.88	8.23	3.94	7.25	6.41	.81	1.69	.88	5.05	.594
450000	2.625	4.500	8.25	13.50	6.88	4.75	11.50	9.50	17.13	9.61	5.31	8.25	7.38	.88	2.25	1.00	5.90	.656
520000	2.625	5.167	9.00	14.94	7.63	5.38	13.00	10.75	19.13	10.27	5.84	9.25	8.03	.94	2.19	1.13	6.55	.781

OUTPUT SHAFT

SIZE	M	N	O	KEYWAY
130000	1.75	.6240	1.50	.19 X .09
180000	2.56	.7490	2.31	.19 X .09
210000	2.53	.8740	2.34	.19 X .09
240000	2.81	.9990	2.63	.25 X .13
260000	2.79	1.1240	2.53	.25 X .13
320000	3.17	1.2490	2.97	.25 X .13
380000	3.23	1.4990	3.25	.38 X .19
450000	3.82	1.6240	3.88	.38 X .19
520000	4.25	1.7490	4.25	.38 X .19

*MOTOR FLANGE DIMENSIONS

MOTOR FRAME	AJ	AK	BD	BE	BF	BORE	KEYWAY
C = 56C	5.88	4.50	6.50	31	.422	.6260	.19 X .09
L = ^{143TC} 145TC	5.88	4.50	6.50	31	.422	.8760	.19 X .09

ASSEMBLIES

STYLE N*D

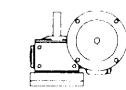

SUFFIX A

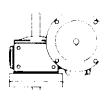

B

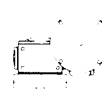

C

STYLE NA*D



A



B

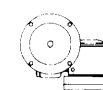

C

STYLE MT*D-MTA*D

SECONDARY WORM TOP
COUPLED C-FACE INPUT
CAST ON BASE
DOUBLE REDUCTION

DIMENSIONS

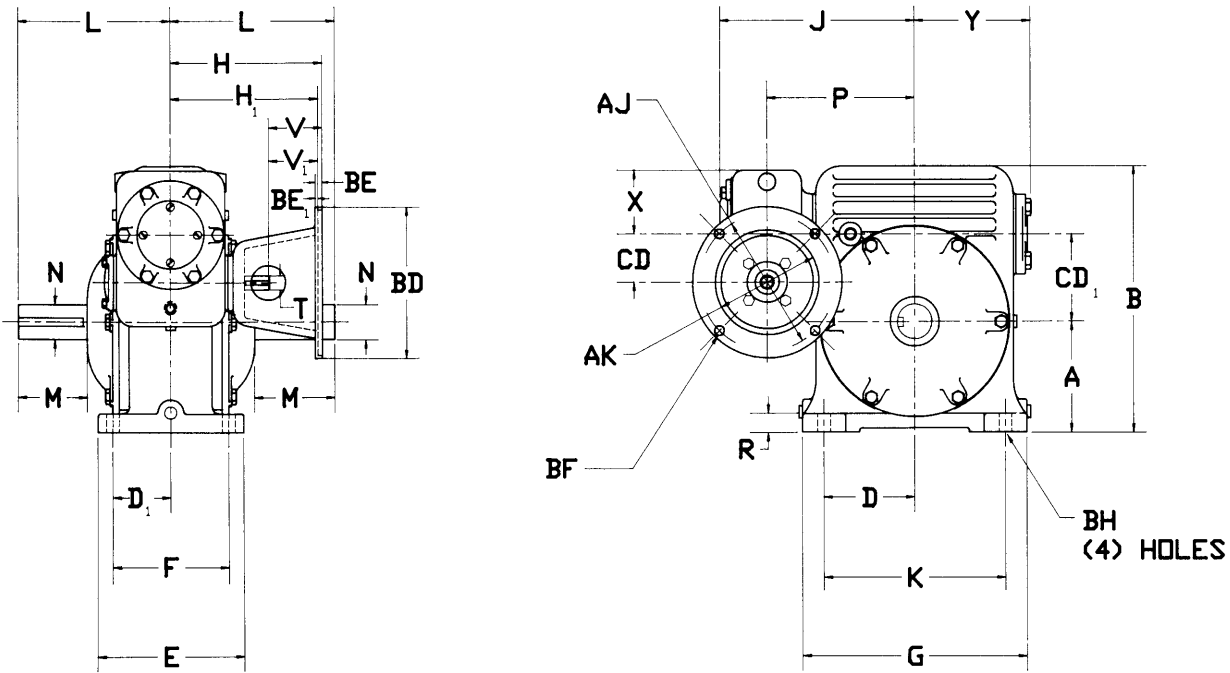

SIZE	CD	CD ₁	A	B	D	D ₁	E	F	G	H	H ₁	J	K	L	P	R	X	Y	BH
**130000	1.333	1.333	1.88	4.63	1.63	1.63	4.00	3.25	4.00	5.91	---	5.55	3.25	3.25	3.50	.38	2.70	2.51	.281
**180000	1.333	1.750	2.25	5.63	2.00	1.75	4.50	3.50	5.00	5.91	---	5.93	4.00	3.50	3.87	.38	2.70	2.88	.406
210000	1.750	2.063	3.13	7.06	2.38	2.06	5.13	4.13	5.75	6.29	---	6.37	4.75	4.25	4.31	.50	1.88	3.16	.406
240000	1.750	2.375	3.50	8.00	2.75	2.06	5.13	4.13	6.50	6.29	---	6.87	5.50	4.06	4.81	.56	1.88	3.57	.406
260000	1.750	2.625	3.63	8.63	2.94	2.38	5.75	4.75	7.00	6.29	---	6.99	5.88	5.00	4.94	.63	1.88	3.69	.469
320000	2.063	3.250	4.38	10.38	3.75	2.50	6.25	5.00	8.88	6.60	---	8.18	7.50	5.44	5.91	.88	2.75	4.55	.531
380000	2.063	3.750	4.75	11.44	3.94	2.53	6.38	5.06	9.75	6.60	---	8.68	7.88	6.69	6.41	.81	2.75	5.05	.531
450000	2.625	4.500	5.50	13.56	4.53	2.75	7.00	5.50	10.75	7.91	7.63	9.90	9.06	7.25	7.38	.88	3.22	5.90	.563
520000	2.625	5.167	6.00	14.75	5.13	2.95	7.63	5.91	12.31	7.91	7.63	10.55	10.25	7.81	8.04	.94	3.22	6.55	.688

ASSEMBLIES

STYLE MT*D

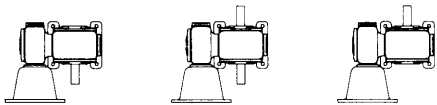

SUFFIX

A

B

C

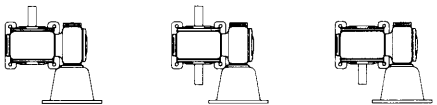

STYLE MTA*D

INPUT SHAFT

SIZE	T	V	V ₁	KEYWAY
130000	.4990	2.41	---	.13 X .06
180000	.4990	2.41	---	.13 X .06
210000	.4990	2.29	---	.13 X .06
240000	.4990	2.29	---	.13 X .06
260000	.4990	2.29	---	.13 X .06
320000	.6240	2.29	---	.19 X .09
380000	.6240	2.29	---	.19 X .09
450000	.7490	2.29	2.93	.19 X .09
520000	.7490	2.29	2.93	.19 X .09

OUTPUT SHAFT

M	N	KEYWAY
1.50	.6240	.19 X .09
1.75	.7490	.19 X .09
1.97	.8740	.19 X .09
1.72	.9990	.25 X .13
2.25	1.1240	.25 X .13
2.44	1.2490	.25 X .13
3.00	1.4990	.38 X .19
3.19	1.6240	.38 X .19
3.53	1.7490	.38 X .19

*MOTOR FLANGE DIMENSIONS

MOTOR FRAME	AJ	AK	BD	BE	BE ₁	BF
C = 56C	5.88	4.50	6.50	.41	---	.406
L = ^{143TC} _{145TC}	5.88	4.50	6.50	.41	---	.406
G = ^{182TC} _{184TC}	7.25	8.50	9.00	---	.22	.531

H₁ and V₁ FOR 182TC, 184TC ONLY

**Primary input top. Motor adapter center line to base = A + CD₁ + CD

For ratings see page 14, 15 • For ordering information see page 16 • For couplings see page 61
Dimensions shown are for reference only • Certified prints available upon request • For mounting positions see page 68
Service and maintenance see page 69

**CIRCULAR BASE
COUPLED C-FACE INPUT
VERTICAL SHAFT
DOUBLE REDUCTION**

STYLE MV*D-MVA*D

DIMENSIONS

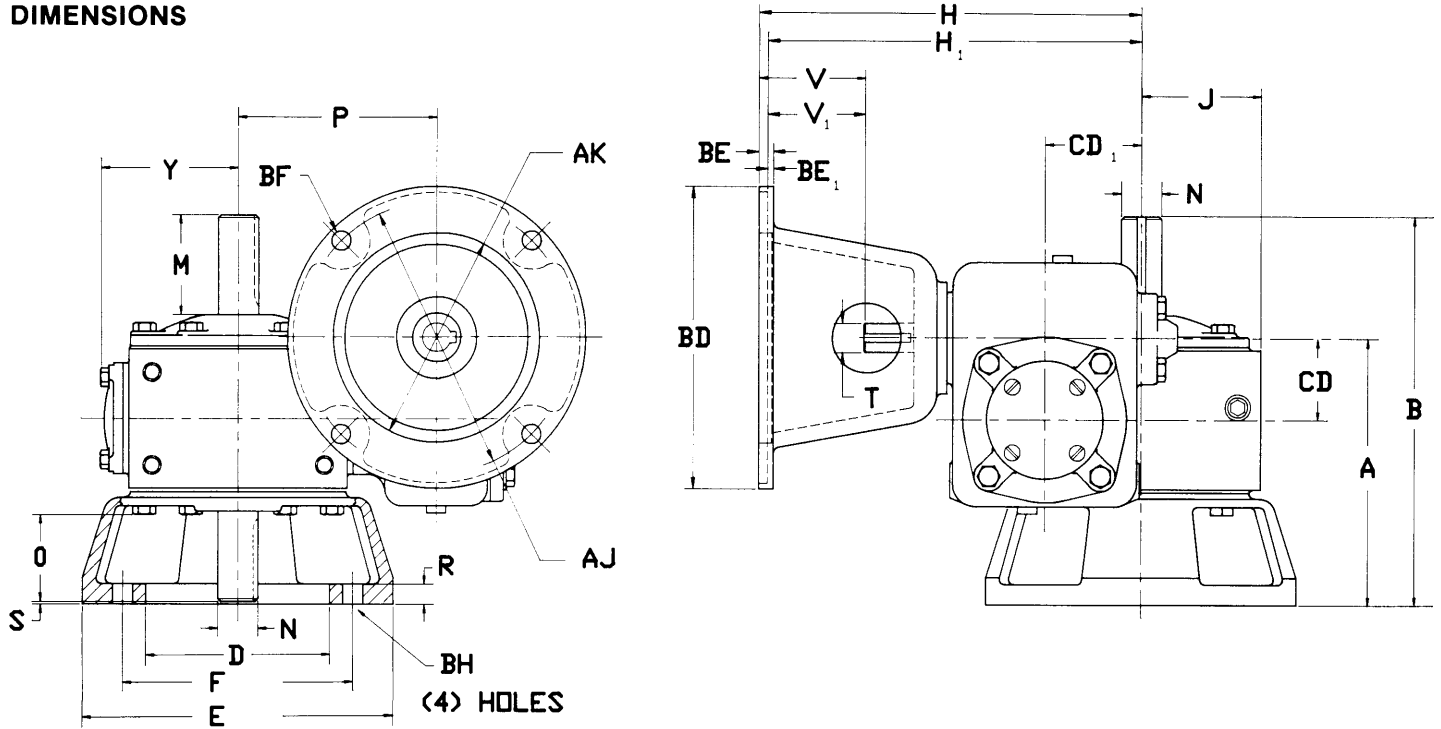

SIZE	CD	CD ₁	A	B	D	E	F	H	H ₁	J	P	R	S	Y	BH
130000	1.333	1.333	4.33	6.31	3.38	4.88	4.00	7.24	---	1.56	3.50	.28	.063	2.51	.281
180000	1.333	1.750	4.58	6.75	3.63	5.63	4.13	7.66	---	1.88	3.87	.31	.063	2.88	.281
210000	1.750	2.063	5.75	8.38	4.00	6.75	5.00	8.35	---	2.44	4.31	.44	.063	3.16	.406
240000	1.750	2.375	6.13	8.69	4.63	7.44	5.63	8.66	---	2.75	4.81	.47	.063	3.57	.406
260000	1.750	2.625	6.38	9.72	5.50	7.69	6.25	8.91	---	2.94	4.94	.50	.063	3.69	.406
320000	2.063	3.250	7.06	10.44	6.00	9.38	7.00	9.85	---	3.25	5.91	.56	.063	4.55	.531
380000	2.063	3.750	7.44	11.31	6.50	10.50	7.75	10.35	---	3.94	6.41	.63	.063	5.05	.531
450000	2.625	4.500	8.63	12.91	7.50	12.00	9.00	12.41	12.13	5.31	7.38	.63	.063	5.90	.531
520000	2.625	5.167	9.13	13.78	8.50	13.81	10.25	13.08	12.80	5.84	8.04	.69	.063	6.55	.531

INPUT SHAFT

SIZE	T	V	V ₁	KEYWAY
130000	.4990	2.41	---	.13 X .06
180000	.4990	2.41	---	.13 X .06
210000	.4990	2.29	---	.13 X .06
240000	.4990	2.29	---	.13 X .06
260000	.4990	2.29	---	.13 X .06
320000	.6240	2.29	---	.19 X .09
380000	.6240	2.29	---	.19 X .09
450000	.7490	2.29	2.93	.19 X .09
520000	.7490	2.29	2.93	.19 X .09

OUTPUT SHAFT

M	N	O	KEYWAY
1.50	.6240	1.38	.19 X .09
1.75	.7490	1.56	.19 X .09
2.09	.8740	1.94	.19 X .09
1.96	.9990	1.66	.25 X .13
2.34	1.1240	2.13	.25 X .13
2.44	1.2490	2.22	.25 X .13
2.23	1.4990	2.25	.38 X .19
2.84	1.6240	2.84	.38 X .19
2.96	1.7490	2.97	.38 X .19

ASSEMBLIES

STYLE MV*D

SUFFIX

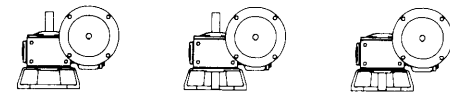

A

B

C

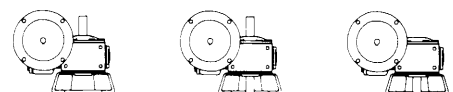

STYLE MVA*D

***MOTOR FLANGE DIMENSIONS**

MOTOR FRAME	AJ	AK	BD	BE	BE ₁	BF
C = 56C	5.88	4.50	6.50	.41	---	.406
L = ^{143TC} _{145TC}	5.88	4.50	6.50	.41	---	.406
G = ^{182TC} _{184TC}	7.25	8.50	9.00	---	.22	.531

H₁ and V₁ FOR 182TC, 184TC ONLY

For ratings see page 14, 15 • For ordering information see page 16 • For couplings see page 61
Dimensions shown are for reference only • Certified prints available upon request • For mounting positions see page 68
Service and maintenance see page 69



STYLE MR*D-MRA*D

HIGH RECTANGULAR BASE
COUPLED C-FACE INPUT
VERTICAL SHAFT
DOUBLE REDUCTION

DIMENSIONS

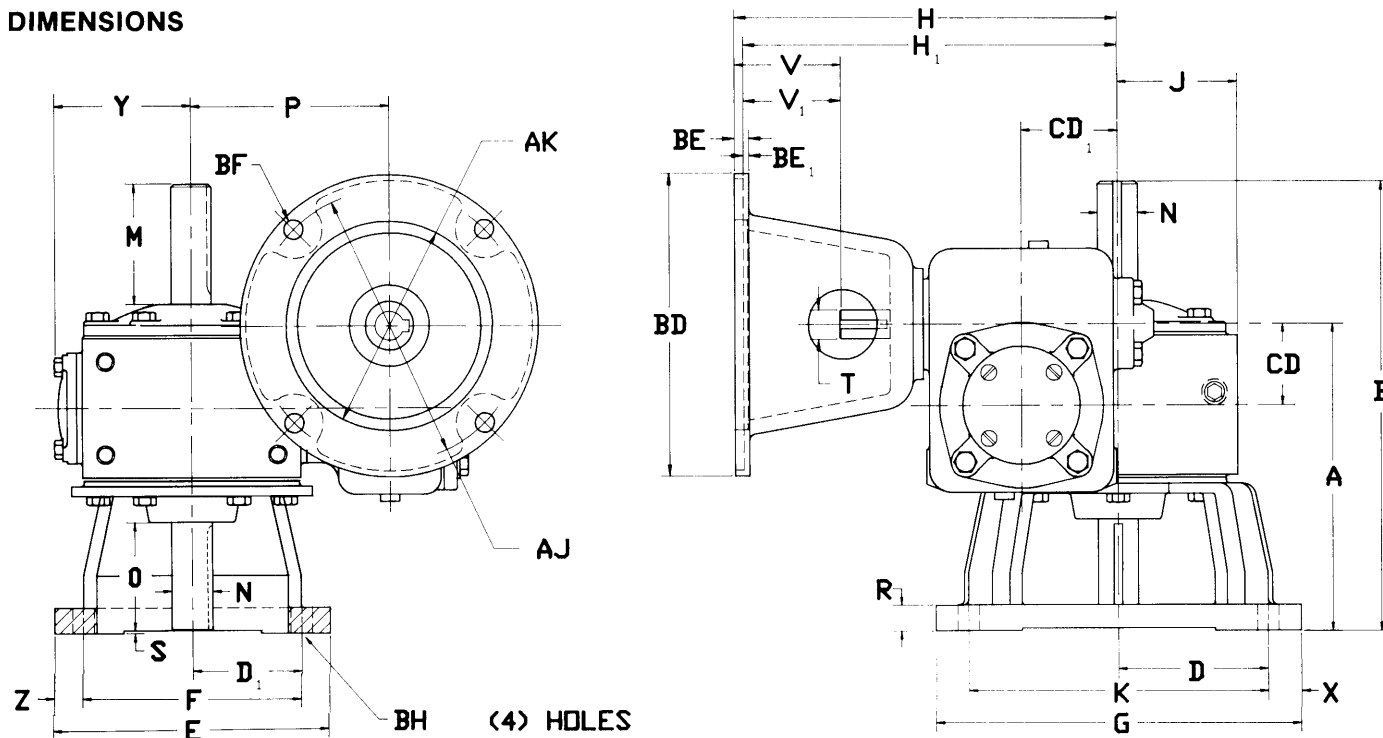

SIZE	CD	CD ₁	A	B	D	D ₁	E	F	G	H	H ₁	J	K	P	R	S	X	Y	Z	BH
130000	1.333	1.333	4.89	7.06	2.25	1.69	4.25	3.38	5.50	7.24	---	1.56	4.50	3.50	.44	.063	.50	2.51	.44	.344
180000	1.333	1.750	5.71	8.69	2.97	2.16	5.50	4.31	7.19	7.66	---	1.88	5.94	3.87	.50	.063	.63	2.88	.59	.406
210000	1.750	2.063	6.63	9.69	3.25	2.38	6.00	4.75	7.94	8.35	---	2.44	6.50	4.31	.56	.063	.72	3.16	.63	.469
240000	1.750	2.375	7.00	10.44	3.63	2.69	6.69	5.38	8.69	8.66	---	2.75	7.25	4.81	.63	.063	.72	3.57	.66	.469
260000	1.750	2.625	7.34	11.13	4.03	2.97	7.38	5.94	9.69	8.91	---	2.94	8.06	4.94	.63	.063	.81	3.69	.72	.531
320000	2.063	3.250	8.31	12.44	4.75	3.56	8.63	7.13	11.19	9.85	---	3.25	9.50	5.91	.75	.063	.84	4.55	.75	.531
380000	2.063	3.750	9.06	13.94	5.41	4.03	9.75	8.06	12.63	10.35	---	3.94	10.81	6.41	.81	.063	.91	5.05	.84	.594
450000	2.625	4.500	10.57	15.81	6.13	4.56	11.13	9.13	14.38	12.41	12.13	5.31	12.25	7.38	.88	.063	1.06	5.90	1.00	.656
520000	2.625	5.167	11.25	17.19	7.13	5.25	12.75	10.50	16.63	13.08	12.80	5.84	14.25	8.04	.94	.063	1.19	6.55	1.13	.781

ASSEMBLIES

STYLE MR*D

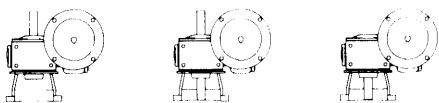

SUFFIX

A

B

C

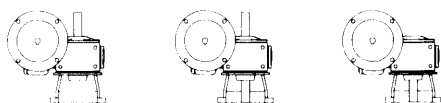

STYLE MRA*D

INPUT SHAFT

SIZE	T	V	V ₁	KEYWAY
130000	4990	2.41	---	.13 X .06
180000	4990	2.41	---	.13 X .06
210000	4990	2.29	---	.13 X .06
240000	4990	2.29	---	.13 X .06
260000	4990	2.29	---	.13 X .06
320000	6240	2.29	---	.19 X .09
380000	6240	2.29	---	.19 X .09
450000	7490	2.29	2.93	.19 X .09
520000	7490	2.29	2.93	.19 X .09

OUTPUT SHAFT

M	N	O	KEYWAY
1.75	.6240	1.50	.19 X .09
2.56	.7490	2.34	.19 X .09
2.53	.8740	2.34	.19 X .09
2.84	.9990	2.63	.25 X .13
2.79	1.1240	2.53	.25 X .13
3.17	1.2490	2.97	.25 X .13
3.23	1.4990	3.25	.38 X .19
3.82	1.6240	3.88	.38 X .19
4.25	1.7490	4.25	.38 X .19

*MOTOR FLANGE DIMENSIONS

MOTOR FRAME	AJ	AK	BD	BE	BE ₁	BF
C = 56C	5.88	4.50	6.50	.41	---	.406
L = 143TC 145TC	5.88	4.50	6.50	.41	---	.406
G = 182TC 184TC	7.25	8.50	9.00	---	.22	.531

H₁ and V₁ FOR 182TC, 184TC ONLY

For ratings see page 14, 15 • For ordering information see page 16 • For couplings see page 61
Dimensions shown are for reference only • Certified prints available upon request • For mounting positions see page 68
Service and maintenance see page 69

HOW TO ORDER MODULAR WORM GEAR REDUCERS

When ordering PLEASE use model number. The examples below may be used to form a model number when the size, ratio and assembly have been determined.

K	A	C	D	18	1200	A
Unit Style	Relative Position (Option)	Motor Code	Other (Options)	Size	Ratio	Shaft Extensions

UNIT STYLE:

See Dimension Pages or Selection Guide Pages 4, 5 & 6

RELATIVE POSITION IN-PUT OUTPUT (OPTION):

A - See Dimension Pages.

MOTOR CODE:

- C - 56C Motor Code
- L - 140TC Motor Code
- G - 180TC Motor Code

OTHER OPTIONS:

- D - Double Reduction
- F - Fan Cooled Option

BASES:

Must be ordered separately see page 59

SIZE:

- 13 = 1.333 C.D.
- 18 = 1.750 C.D.
- 21 = 2.063 C.D.
- 24 = 2.375 C.D.
- 26 = 2.625 C.D.
- 32 = 3.250 C.D.
- 38 = 3.750 C.D.

RATIO (Examples)

- Single Reduction
 - 5:1 = 05
 - 60:1 = 60
- Double Reduction
 - 75:1 = 0075
 - 400:1 = 0400
 - 3600:1 = 3600

SHAFT EXTENSIONS:

See Assembly Drawing on Dim. Pages

MODEL NUMBER EXAMPLES:

- | | | | | | | | | | | | | |
|---------------------------|----|---|---|---|---|---|---|---|---|---|---|---|
| Single Reduction Examples | 1) | | H | A | C | H | 1 | 8 | 3 | 0 | B | |
| | 2) | | | | H | F | 3 | 8 | 6 | 0 | C | |
| | 3) | | K | L | H | F | 3 | 2 | 2 | 0 | A | |
| Double Reduction Examples | 1) | K | A | C | H | D | 1 | 8 | 0 | 4 | 0 | A |
| | 2) | | | | H | H | 3 | 2 | 1 | 8 | 0 | B |
| | 3) | | | | H | L | 3 | 8 | 0 | 0 | 7 | C |

DIMENSIONS

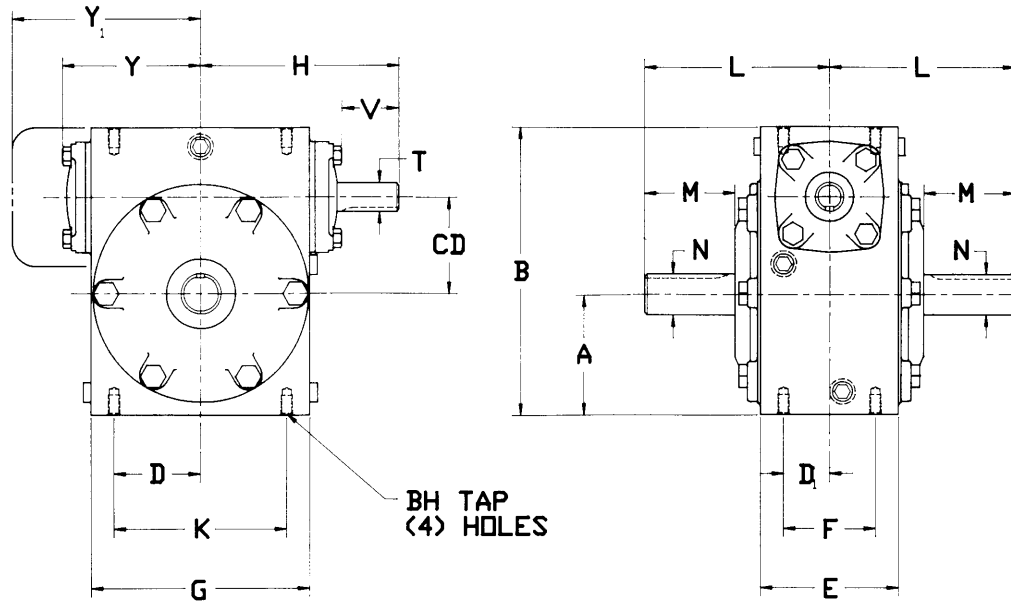

SIZE	C.D.	A	B	D	D ₁	E	F	G	H	K	L	Y	Y ₁	BH
1300	1.333	1.56	4.09	1.25	.81	2.38	1.63	3.25	3.50	2.50	3.25	2.27	---	1/4-20
1800	1.750	1.88	5.00	1.56	.81	2.38	1.63	4.00	4.00	3.13	3.50	2.65	---	1/4-20
2100	2.063	2.44	6.00	1.88	1.00	3.00	2.00	4.75	4.31	3.75	4.25	3.02	---	5/16-18
2400	2.375	2.75	6.88	2.44	1.19	3.13	2.38	5.63	5.25	4.88	4.06	3.58	---	3/8-16
2600	2.625	2.94	7.44	2.44	1.34	3.50	2.69	6.00	5.63	4.88	5.00	3.71	---	3/8-16
(F)3200	3.250	3.25	8.63	3.13	1.38	3.88	2.75	7.50	6.88	6.25	5.44	4.57	7.13	1/2-13
(F)3800	3.750	3.94	10.06	3.44	1.50	4.25	3.00	8.56	7.50	6.88	6.69	5.07	7.81	1/2-13

INPUT SHAFT

SIZE	T	V	KEYWAY
1300	.4990	1.38	.13 × .06
1800	.4990	1.50	.13 × .06
2100	.6240	1.41	.19 × .09
2400	.7490	1.69	.19 × .09
2600	.7490	1.94	.19 × .09
(F)3200	.8740	2.44	.19 × .09
(F)3800	.9990	2.56	.25 × .13

OUTPUT SHAFT

M	N*	KEYWAY
1.50	.6240	.19 × .09
1.75	.7490	.19 × .09
1.97	.8740	.19 × .09
1.72	.9990	.25 × .13
2.25	1.1240	.25 × .13
2.44	1.2490	.25 × .13
3.00	1.4990	.38 × .19

ASSEMBLIES

STYLE H

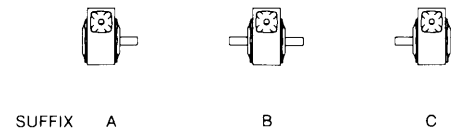

SUFFIX A B C

*Optional output shaft diameters available for units with 1.75 C.D. and above. Consult factory.

STYLE HH-HHF

MODULAR HOUSING
HOLLOW OUTPUT SHAFT
FAN COOLED OPTIONAL

DIMENSIONS

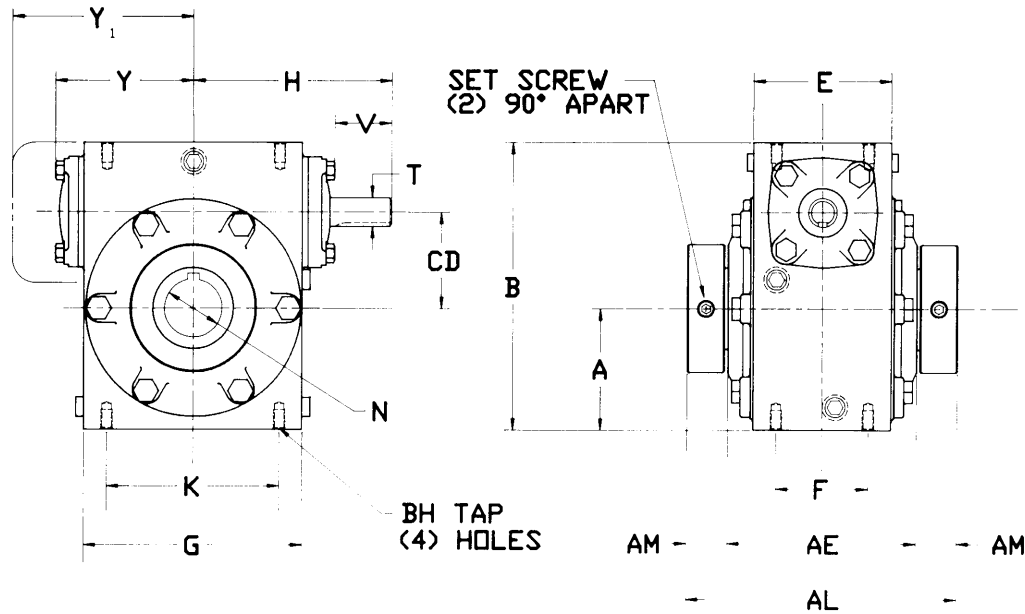

SIZE	C.D.	A	B	E	F	G	H	K	Y	Y ₁	AE	AL	AM	BH
1800	1.750	1.88	5.00	2.38	1.63	4.00	4.00	3.13	2.65	---	3.50	4.80	.65	1/4-20
2100	2.063	2.44	6.00	3.00	2.00	4.75	4.31	3.75	3.02	---	4.18	5.88	.85	5/16-18
2400	2.375	2.75	6.88	3.13	2.38	5.63	5.25	4.88	3.58	---	4.92	6.54	.81	3/8-16
2600	2.625	2.94	7.44	3.50	2.69	6.00	5.63	4.88	3.71	---	4.98	6.54	.78	3/8-16
(F)3200	3.250	3.25	8.63	3.88	2.75	7.50	6.88	6.25	4.57	7.13	5.64	7.26	.81	1/2-13
(F)3800	3.750	3.94	10.06	4.25	3.00	8.56	7.50	6.88	5.07	7.81	6.20	7.76	.78	1/2-13

INPUT SHAFT

SIZE	T	V	KEYWAY
1800	.4990	1.50	.13 × .06
2100	.6240	1.41	.19 × .09
2400	.7490	1.69	.19 × .09
2600	.7490	1.94	.19 × .09
(F)3200	.8740	2.44	.19 × .09
(F)3800	.9990	2.56	.25 × .13

HOLLOW BORE

N*	KEY
1.000	1/4 × 1/4
1.250	1/4 × 1/4
1.688	3/8 × 11/32
1.688	3/8 × 11/32
2.188	1/2 × 3/8
2.438	1/2 × 3/8

*Diameter is maximum. Bushings are available for smaller diameters. See page 62.

**SQUARE FLANGED
MODULAR HOUSING
HOLLOW OUTPUT SHAFT
FAN COOLED OPTIONAL**

STYLE KH-KAH

DIMENSIONS

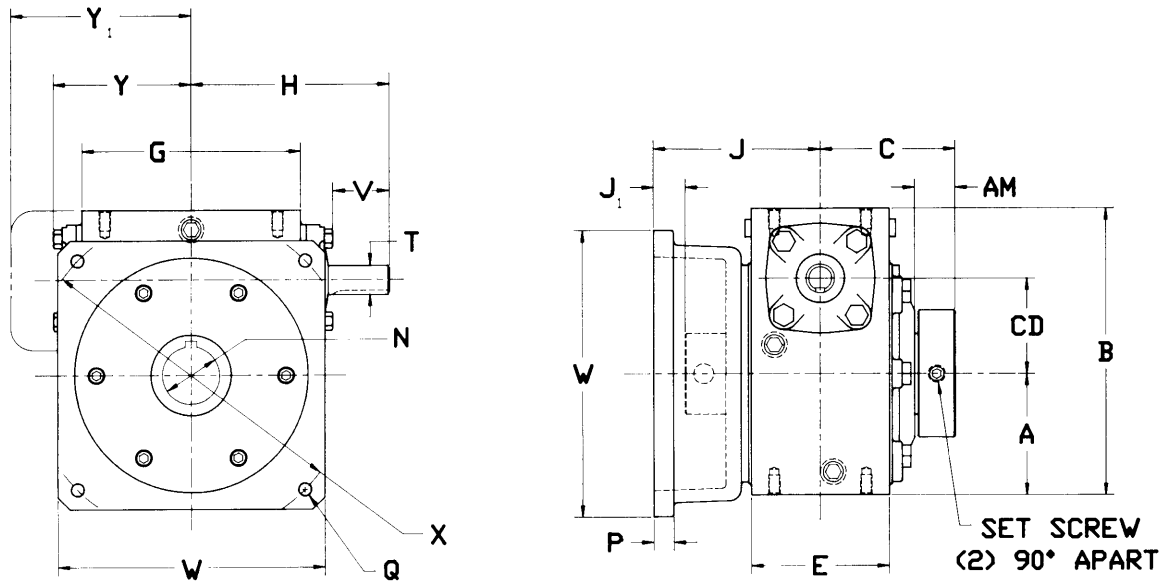

SIZE	C.D.	A	B	C	E	G	H	J	J ₁	P	Q	W	X	Y	Y ₁	AM
1800	1.750	1.88	5.00	2.40	2.38	4.00	4.00	3.33	.93	.34	.34	5.38	5.88	2.65	---	.65
2100	2.063	2.44	6.00	2.94	3.00	4.75	4.31	3.65	.71	.44	.41	5.81	7.00	3.02	---	.85
2400	2.375	2.75	6.88	3.27	3.13	5.63	5.25	3.65	.38	.38	.41	6.88	7.50	3.58	---	.81
2600	2.625	2.94	7.44	3.27	3.50	6.00	5.63	3.65	.38	.38	.41	6.88	8.00	3.71	---	.78
(F)3200	3.250	3.25	8.63	3.63	3.88	7.50	6.88	4.50	.83	.50	.56	7.75	9.00	4.57	7.13	.81
(F)3800	3.750	3.94	10.06	3.88	4.25	8.56	7.50	5.00	1.13	.50	.56	8.75	10.00	5.07	7.81	.78

INPUT SHAFT

SIZE	T	V	KEYWAY
1800	.4990	1.50	.13 × .06
2100	.6240	1.41	.19 × .09
2400	.7490	1.69	.19 × .09
2600	.7490	1.94	.19 × .09
(F)3200	.8740	2.44	.19 × .09
(F)3800	.9990	2.56	.25 × .13

HOLLOW BORE

N*	KEY
1.000	1/4 × 1/4
1.250	1/4 × 1/4
1.688	3/8 × 11/32
1.688	3/8 × 11/32
2.188	1/2 × 3/8
2.438	1/2 × 3/8

ASSEMBLIES

STYLE KH



STYLE KAH



*Diameter is maximum. Bushings are available for smaller diameters. See page 62.

STYLE H*-H*F

MODULAR HOUSING
QUILLED C-FACE INPUT
FAN COOLED OPTIONAL

DIMENSIONS

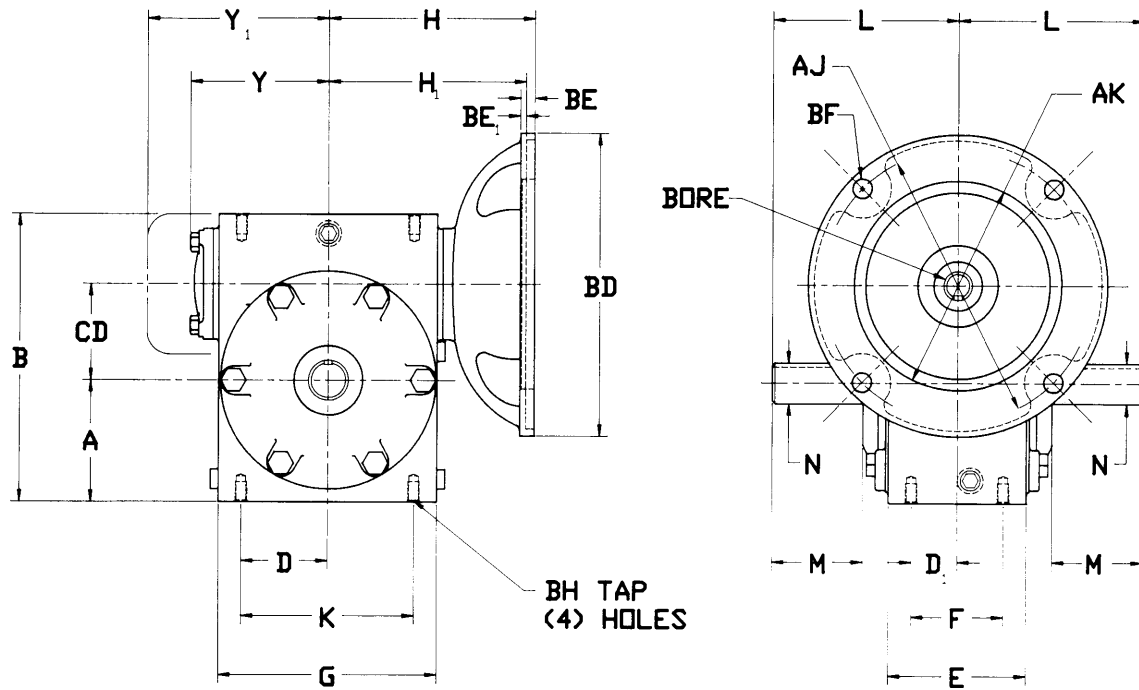

SIZE	C.D.	A	B	D	D ₁	E	F	G	H	H ₁	K	L	Y	Y ₁	BH
1300	1.333	1.56	4.09	1.25	.81	2.38	1.63	3.25	3.73	---	2.50	3.25	2.51	---	1/4-20
1800	1.750	1.88	5.00	1.56	.81	2.38	1.63	4.00	4.11	---	3.13	3.50	2.88	---	1/4-20
2100	2.063	2.44	6.00	1.88	1.00	3.00	2.00	4.75	4.48	---	3.75	4.25	3.16	---	5/16-18
2400	2.375	2.75	6.88	2.44	1.19	3.13	2.38	5.63	4.98	---	4.88	4.06	3.57	---	3/8-16
2600	2.625	2.94	7.44	2.44	1.34	3.50	2.69	6.00	5.11	---	4.88	5.00	3.69	---	3/8-16
(F)3200	3.250	3.25	8.63	3.13	1.38	3.88	2.75	7.50	5.85	5.60	6.25	5.44	4.55	7.13	1/2-13
(F)3800	3.750	3.94	10.06	3.44	1.50	4.25	3.00	8.56	6.35	6.10	6.88	6.69	5.05	7.81	1/2-13

*MOTOR FLANGE DIMENSIONS

MOTOR FRAME	AJ	AK	BD	BE	BE ₁	BF	BORE	KEYWAY
C = 56C	5.88	4.50	6.50	.31	---	.422	.6260	.19 X .09
L = ^{143TC} _{145TC}	5.88	4.50	6.50	.31	---	.422	.8760	.19 X .09
G = ^{182TC} _{184TC}	7.25	8.50	8.91	---	.38	.531	1.1260	.25 X .12

OUTPUT SHAFT

SIZE	M	N**	KEYWAY
1300	1.50	.6240	.19 X .09
1800	1.75	.7490	.19 X .09
2100	1.97	.8740	.19 X .09
2400	1.72	.9990	.25 X .13
2600	2.25	1.1240	.25 X .13
(F)3200	2.44	1.2490	.25 X .13
(F)3800	3.00	1.4990	.38 X .19

ASSEMBLIES

STYLE H*

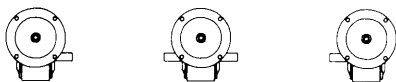

SUFFIX

A

B

C

H₁ FOR 182TC, 184TC ONLY

**Optional output shaft diameters available for units with 1.75 C.D. and above. Consult factory.

**MODULAR HOUSING
QUILLED C-FACE INPUT
HOLLOW OUTPUT SHAFT
FAN COOLED OPTIONAL**

STYLE H*H-H*HF

DIMENSIONS

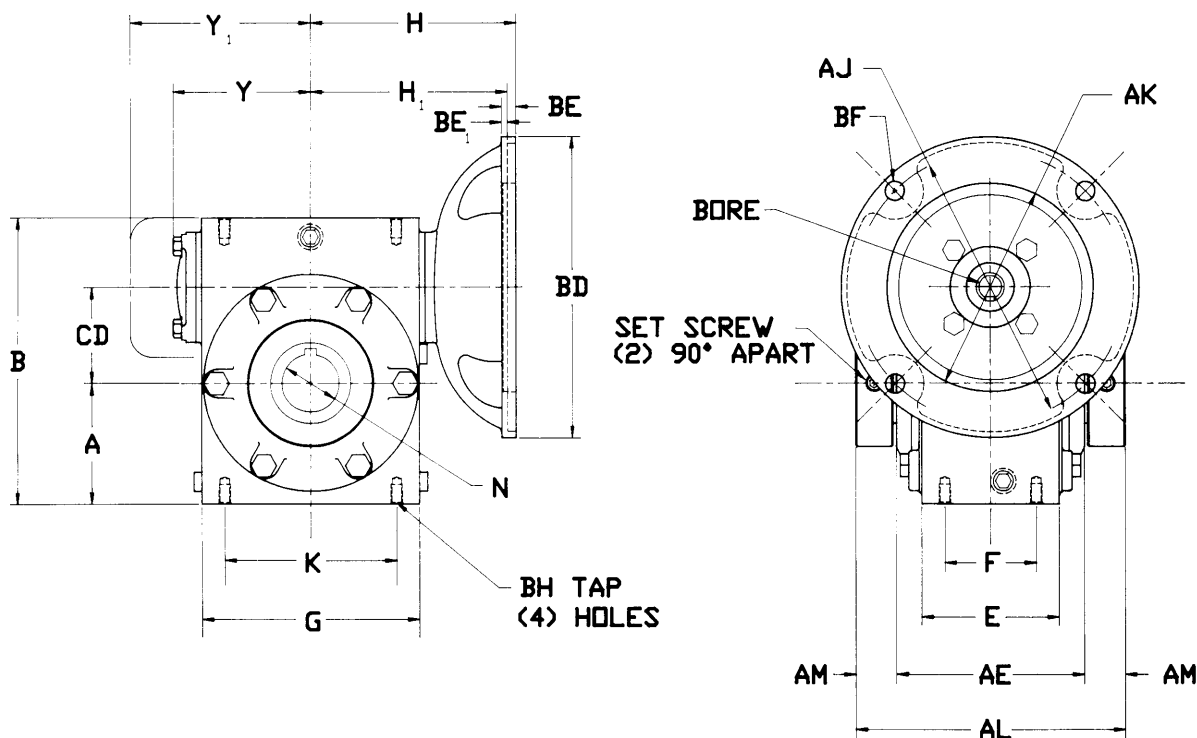

SIZE	C.D.	A	B	E	F	G	H	H ₁	K	Y	Y ₁	AE	AL	AM	BH
1800	1.750	1.88	5.00	2.38	1.63	4.00	4.11	---	3.13	2.88	---	3.50	4.80	.65	1/4-20
2100	2.063	2.44	6.00	3.00	2.00	4.75	4.48	---	3.75	3.16	---	4.18	5.88	.85	5/16-18
2400	2.375	2.75	6.88	3.13	2.38	5.63	4.98	---	4.88	3.57	---	4.92	6.54	.81	3/8-16
2600	2.625	2.94	7.44	3.50	2.69	6.00	5.11	---	4.88	3.69	---	4.98	6.54	.78	3/8-16
(F)3200	3.250	3.25	8.63	3.88	2.75	7.50	5.85	5.60	6.25	4.55	7.13	5.64	7.26	.81	1/2-13
(F)3800	3.750	3.94	10.06	4.25	3.00	8.56	6.35	6.10	6.88	5.05	7.81	6.20	7.76	.78	1/2-13

*MOTOR FLANGE DIMENSIONS

MOTOR FRAME	AJ	AK	BD	BE	BE ₁	BF	BORE	KEYWAY
C = 56C	5.88	4.50	6.50	.31	---	.422	.6260	.19 X .09
L = ^{143TC} _{145TC}	5.88	4.50	6.50	.31	---	.422	.8760	.19 X .09
G = ^{182TC} _{184TC}	7.25	8.50	8.91	---	.38	.531	1.1260	.25 X .12

H₁ FOR 182TC, 184TC ONLY

HOLLOW BORE

SIZE	N**	KEY
1800	1.000	1/4 X 1/4
2100	1.250	1/4 X 1/4
2400	1.688	3/8 X 11/32
2600	1.688	3/8 X 11/32
(F)3200	2.188	1/2 X 3/8
(F)3800	2.438	1/2 X 3/8

**Diameter is maximum. Bushings are available for smaller diameters. See page 62

STYLE K*H-K*HF

SQUARE FLANGED
MODULAR HOUSING
QUILLED C-FACE INPUT
HOLLOW OUTPUT SHAFT
FAN COOLED OPTIONAL

DIMENSIONS

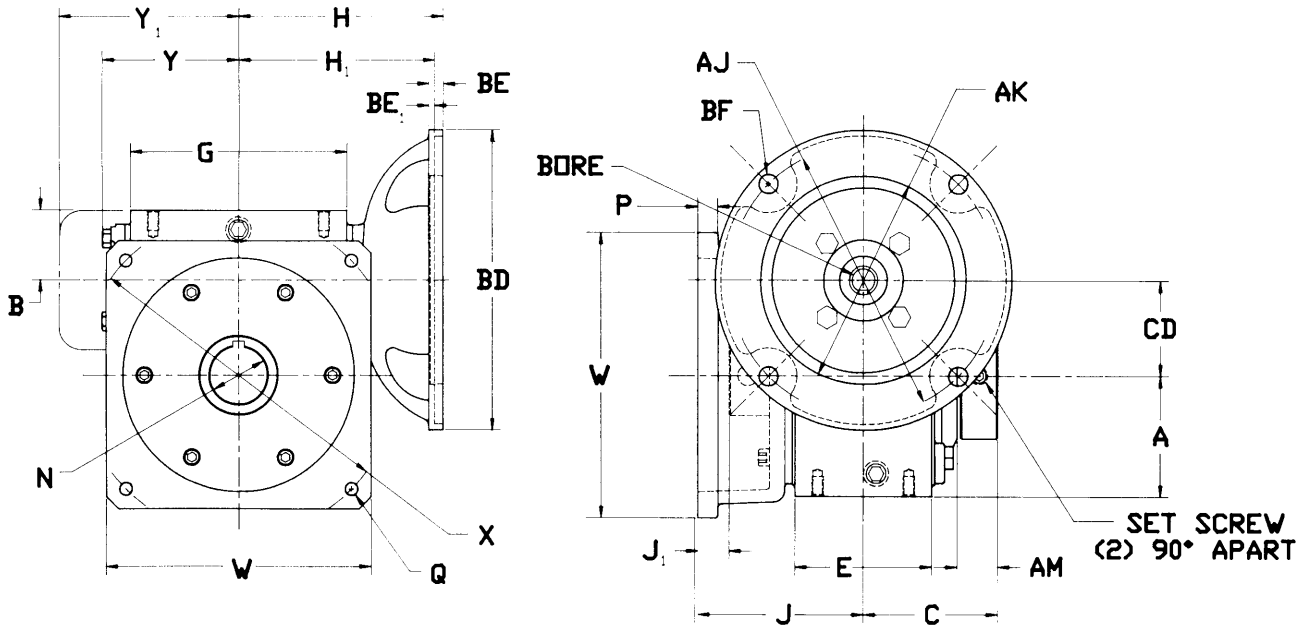

SIZE	C.D.	A	B	C	E	G	H	H ₁	J	J ₁	P	Q	W	X	Y	Y ₁	AM
1800	1.750	1.88	1.38	2.40	2.38	4.00	4.11	---	3.33	.93	.34	.34	5.38	5.88	2.88	---	.65
2100	2.063	2.44	1.50	2.94	3.00	4.75	4.48	---	3.65	.71	.44	.41	5.81	7.00	3.16	---	.85
2400	2.375	2.75	1.75	3.27	3.13	5.63	4.98	---	3.65	.38	.38	.41	6.88	7.50	3.57	---	.81
2600	2.625	2.94	1.88	3.27	3.50	6.00	5.11	---	3.65	.38	.38	.41	6.88	8.00	3.69	---	.78
(F)3200	3.250	3.25	2.13	3.63	3.88	7.50	5.85	5.60	4.50	.83	.50	.56	7.75	9.00	4.55	7.13	.81
(F)3800	3.750	3.94	2.38	3.88	4.25	8.56	6.35	6.10	5.00	1.13	.50	.56	8.75	10.00	5.05	7.81	.78

*MOTOR FLANGE DIMENSIONS

MOTOR FRAME	AJ	AK	BD	BE	BE ₁	BF	BORE	KEYWAY
C = 56C	5.88	4.50	6.50	.31	---	.422	.6260	.19 X .09
L = 143TC 145TC	5.88	4.50	6.50	.31	---	.422	.8760	.19 X .09
G = 182TC 184TC	7.25	8.50	8.91	---	.38	.531	1.1260	.25 X .12

H₁ FOR 182TC, 184TC ONLY

HOLLOW BORE

SIZE	N**	KEY
1800	1.000	1/4 X 1/4
2100	1.250	1/4 X 1/4
2400	1.688	3/8 X 11/32
2600	1.688	3/8 X 11/32
(F)3200	2.188	1/2 X 3/8
(F)3800	2.438	1/2 X 3/8

ASSEMBLIES

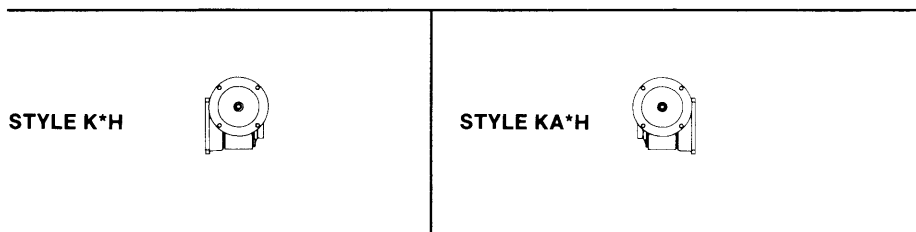

**Diameter is maximum. Bushings are available for smaller diameters. See page 62

For ratings see page 12, 13 • For ordering information see page 44
Dimensions shown are for reference only • Certified prints available upon request • For mounting positions see page 68
Service and maintenance see page 69

**SQUARE FLANGED
MODULAR HOUSING
QUILLED C-FACE INPUT
FAN COOLED OPTIONAL**

STYLE K*-K*F

DIMENSIONS

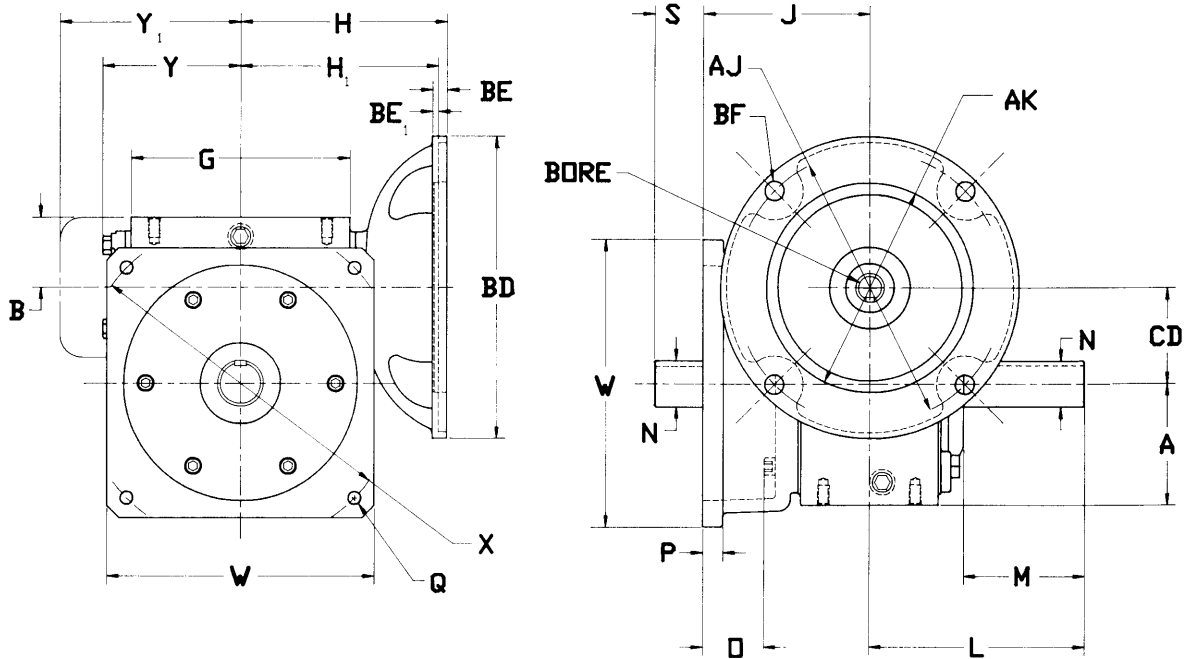

SIZE	C.D.	A	B	G	H	H ₁	J	L	P	Q	S	W	X	Y	Y ₁
1800	1.750	1.88	1.38	4.00	4.11	---	3.33	3.50	.34	.34	.17	5.38	5.88	2.88	---
2100	2.063	2.44	1.50	4.75	4.48	---	3.65	4.25	.44	.41	.60	5.81	7.00	3.16	---
2400	2.375	2.75	1.75	5.63	4.98	---	3.65	4.06	.38	.41	.41	6.88	7.50	3.57	---
2600	2.625	2.94	1.88	6.00	5.11	---	3.65	5.00	.38	.41	1.35	6.88	8.00	3.69	---
(F)3200	3.250	3.25	2.13	7.50	5.85	5.60	4.50	5.44	.50	.56	.94	7.75	9.00	4.55	7.13
(F)3800	3.750	3.94	2.38	8.56	6.35	6.10	5.00	6.69	.50	.56	1.69	8.75	10.00	5.05	7.81

OUTPUT SHAFT

SIZE	M	N**	O	KEYWAY
1800	1.75	.8740	1.33	.19 X .09
2100	1.97	.9990	1.32	.25 X .13
2400	1.75	1.1240	.84	.25 X .13
2600	2.25	1.2490	1.13	.25 X .13
(F)3200	2.47	1.4990	1.37	.38 X .19
(F)3800	3.00	1.6240	1.64	.38 X .19

*MOTOR FLANGE DIMENSIONS

MOTOR FRAME	AJ	AK	BD	BE	BE ₁	BF	BORE	KEYWAY
C = 56C	5.88	4.50	6.50	.31	---	.422	.6260	.19 X .09
L = ^{143TC} / _{145TC}	5.88	4.50	6.50	.31	---	.422	.8760	.19 X .09
G = ^{182TC} / _{184TC}	7.25	8.50	8.91	---	.38	.531	1.1260	.25 X .12

H₁ FOR 182TC, 184TC ONLY

ASSEMBLIES

STYLE K*

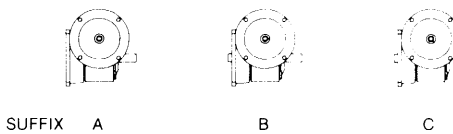

STYLE KA*

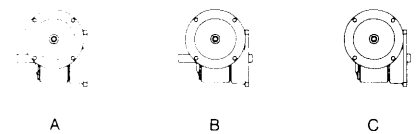

**Optional Output Shaft diameters available consult factory

STYLE HD-HAD

MODULAR HOUSING
DOUBLE REDUCTION

DIMENSIONS

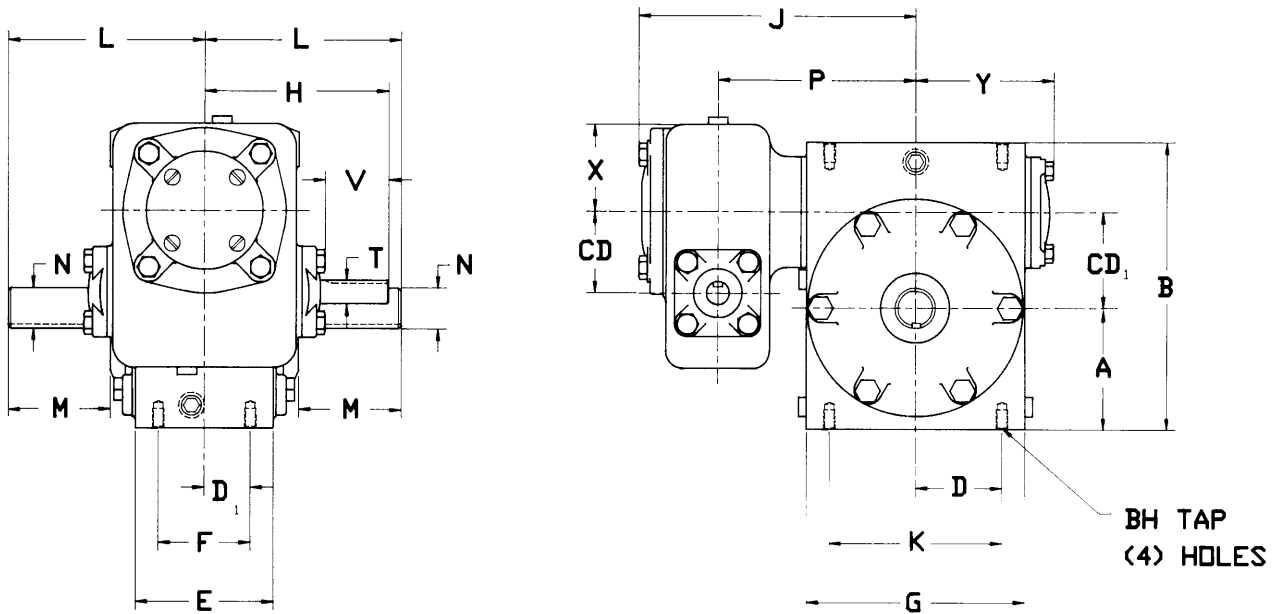

SIZE	CD	CD ₁	A	B	D	D ₁	E	F	G	H	J	K	L	P	X	Y	BH
130000	1.333	1.333	1.56	4.09	1.25	.81	2.38	1.63	3.25	3.50	5.55	2.50	3.25	3.50	1.60	2.51	1/4-20
180000	1.333	1.750	1.88	5.00	1.56	.81	2.38	1.63	4.00	3.50	5.93	3.13	3.50	3.87	1.60	2.88	1/4-20
210000	1.750	2.063	2.44	6.00	1.88	1.00	3.00	2.00	4.75	4.00	6.37	3.75	4.25	4.31	1.88	3.16	5/16-18
240000	1.750	2.375	2.75	6.88	2.44	1.19	3.13	2.38	5.63	4.00	6.87	4.88	4.06	4.81	1.88	3.57	3/8-16
260000	1.750	2.625	2.94	7.44	2.44	1.34	3.50	2.69	6.00	4.00	6.99	4.88	5.00	4.94	1.88	3.69	3/8-16
320000	2.063	3.250	3.25	8.63	3.13	1.38	3.88	2.75	7.50	4.31	8.18	6.25	5.44	5.91	2.75	4.55	1/2-13
380000	2.063	3.750	3.94	10.06	3.44	1.50	4.25	3.00	8.56	4.31	8.68	6.88	6.69	6.41	2.75	5.05	1/2-13

ASSEMBLIES

STYLE HD

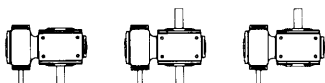

SUFFIX

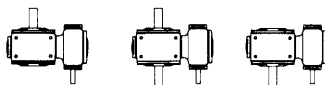

STYLE HAD

INPUT SHAFT

SIZE	T	V	KEYWAY
130000	.4990	1.38	.13 × .06
180000	.4990	1.38	.13 × .06
210000	.4990	1.50	.13 × .06
240000	.4990	1.50	.13 × .06
260000	.4990	1.50	.13 × .06
320000	.6240	1.41	.19 × .09
380000	.6240	1.41	.19 × .09

OUTPUT SHAFT

M	N*	KEYWAY
1.50	.6240	.19 × .09
1.75	.7490	.19 × .09
1.97	.8740	.19 × .09
1.72	.9990	.25 × .13
2.25	1.1240	.25 × .13
2.44	1.2490	.25 × .13
3.00	1.4990	.38 × .19

*Optional output shaft diameters available for units with 1.75 C.D. and above. Consult factory.

**MODULAR HOUSING
HOLLOW SHAFT OUTPUT
DOUBLE REDUCTION**

STYLE HHD-HAHD

DIMENSIONS

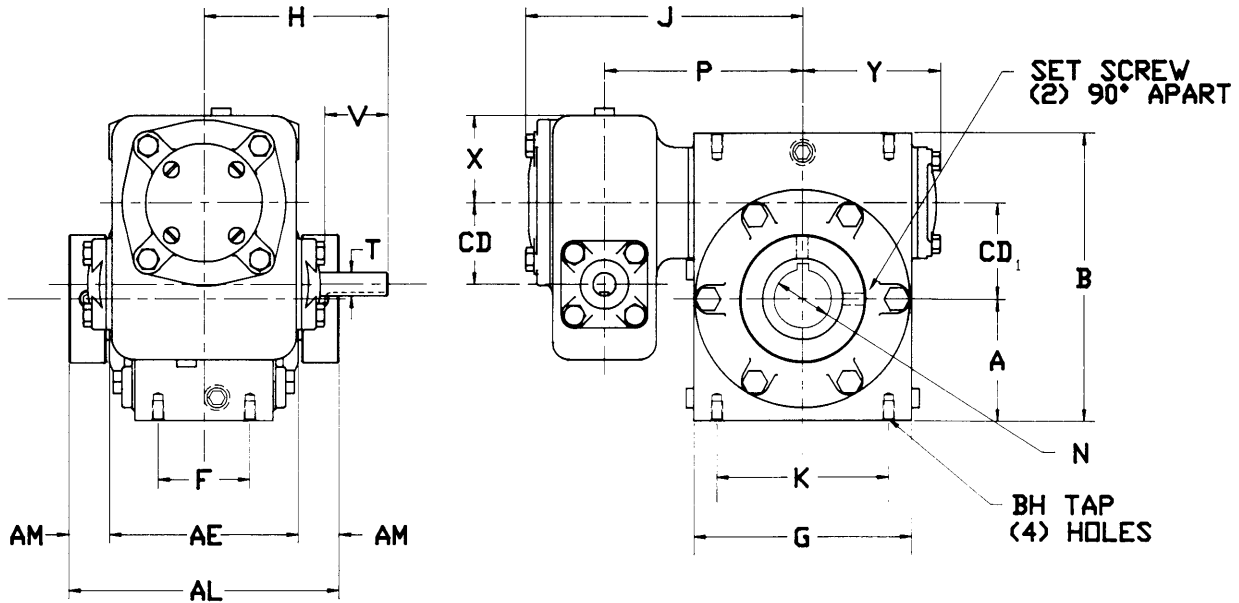

SIZE	CD	CD ₁	A	B	F	G	H	J	K	P	X	Y	AE	AL	AM	BH
180000	1.333	1.750	1.88	5.00	1.63	4.00	3.50	5.93	3.13	3.87	1.60	2.88	3.50	4.80	.65	1/4-20
210000	1.750	2.063	2.44	6.00	2.00	4.75	4.00	6.37	3.75	4.31	1.88	3.16	4.18	5.88	.85	5/16-18
240000	1.750	2.375	2.75	6.88	2.38	5.63	4.00	6.87	4.88	4.81	1.88	3.57	4.92	6.54	.81	3/8-16
260000	1.750	2.625	2.94	7.44	2.69	6.00	4.00	6.99	4.88	4.94	1.88	3.69	4.98	6.54	.78	3/8-16
320000	2.063	3.250	3.25	8.63	2.75	7.50	4.31	8.18	6.25	5.91	2.75	4.55	5.64	7.26	.81	1/2-13
380000	2.063	3.750	3.94	10.06	3.00	8.56	4.31	8.68	6.88	6.41	2.75	5.05	6.20	7.76	.78	1/2-13

INPUT SHAFT

SIZE	T	V	KEYWAY
180000	.4990	1.38	.13 × .06
210000	.4990	1.50	.13 × .06
240000	.4990	1.50	.13 × .06
260000	.4990	1.50	.13 × .06
320000	.6240	1.41	.19 × .09
380000	.6240	1.41	.19 × .09

HOLLOW BORE

N*	KEY
1.000	1/4 × 1/4
1.250	1/4 × 1/4
1.688	3/8 × 11/32
1.688	3/8 × 11/32
2.188	1/2 × 3/8
2.438	1/2 × 3/8

ASSEMBLIES

STYLE HHD



STYLE HAHD



*Diameter is maximum. Bushings are available for smaller diameters. See page 62.

STYLE KHD-KAHD

**SQUARE FLANGED
MODULAR HOUSING
HOLLOW OUTPUT SHAFT
DOUBLE REDUCTION**

DIMENSIONS

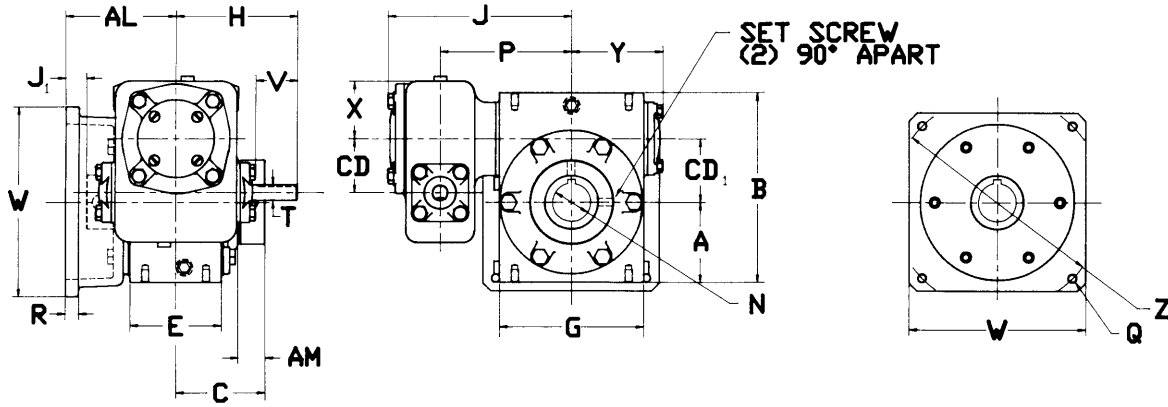

SIZE	CD	CD ₁	A	B	C	E	G	H	J	J ₁	P	Q	R	W	X	Y	Z	AL	AM
180000	1.333	1.750	1.88	5.00	2.40	2.38	4.00	3.50	5.93	.93	3.87	.34	.34	5.38	1.60	2.88	5.88	3.33	.65
210000	1.750	2.063	2.44	6.00	2.94	3.00	4.75	4.00	6.37	.71	4.31	.41	.44	5.81	1.88	3.16	7.00	3.65	.85
240000	1.750	2.375	2.75	6.88	3.27	3.13	5.63	4.00	6.87	.38	4.81	.41	.38	6.88	1.88	3.57	7.50	3.65	.81
260000	1.750	2.625	2.94	7.44	3.27	3.50	6.00	4.00	6.99	.38	4.94	.41	.38	6.88	1.88	3.69	8.00	3.65	.78
320000	2.063	3.250	3.25	8.63	3.63	3.88	7.50	4.31	8.18	.83	5.91	.56	.50	7.75	2.75	4.55	9.00	4.50	.81
380000	2.063	3.750	3.94	10.06	3.88	4.25	8.56	4.31	8.68	1.13	6.41	.56	.50	8.75	2.75	5.05	10.00	5.00	.78

ASSEMBLIES

STYLE KHD



STYLE KAHD



INPUT SHAFT

SIZE	T	V	KEYWAY
180000	.4990	1.38	.13 × .06
210000	.4990	1.50	.13 × .06
240000	.4990	1.50	.13 × .06
260000	.4990	1.50	.13 × .06
320000	.6240	1.41	.19 × .09
380000	.6240	1.41	.19 × .09

HOLLOW BORE

N*	KEY
1.000	1/4 × 1/4
1.250	1/4 × 1/4
1.688	3/8 × 11/32
1.688	3/8 × 11/32
2.188	1/2 × 3/8
2.438	1/2 × 3/8

*Diameter is maximum. Bushings are available for smaller diameters. See page 62.

DIMENSIONS

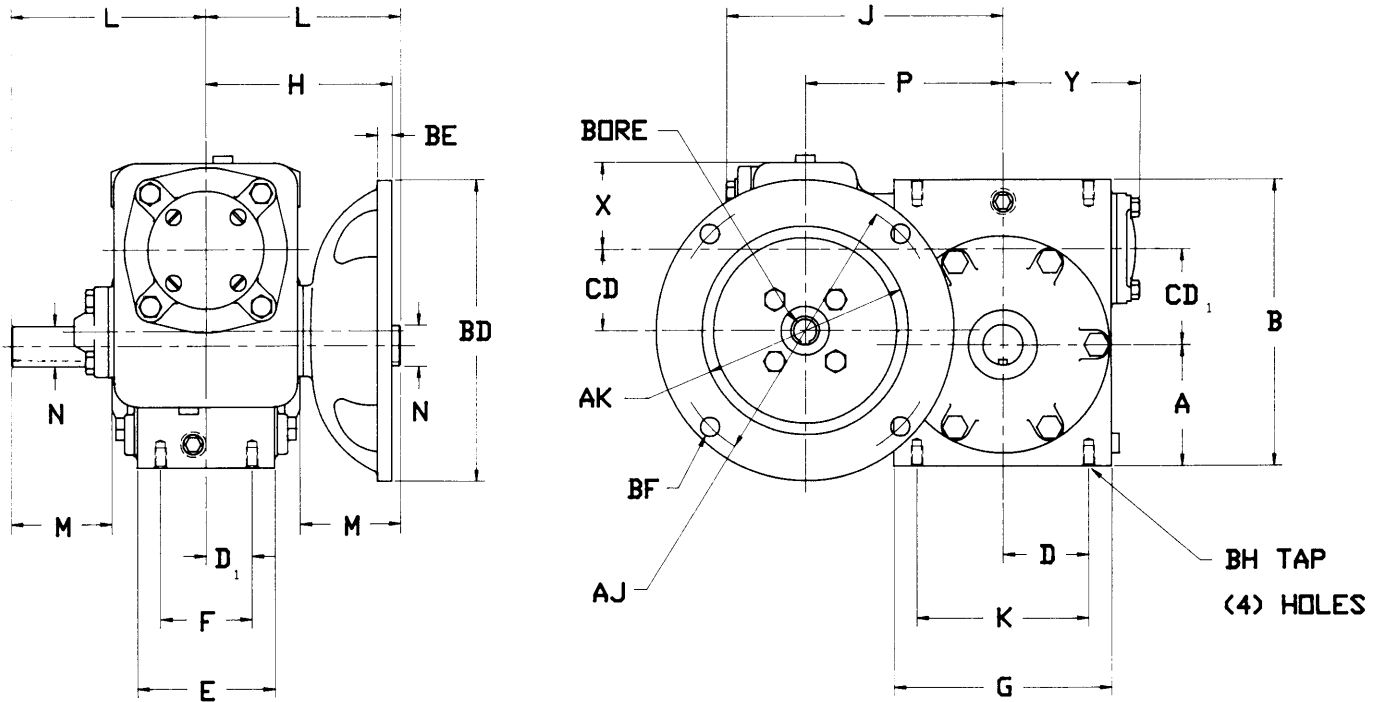

SIZE	CD	CD ₁	A	B	D	D ₁	E	F	G	H	J	K	L	P	X	Y	BH
130000	1.333	1.333	1.56	4.09	1.25	.81	2.38	1.63	3.25	3.73	5.55	2.50	3.25	3.50	1.60	2.51	1/4-20
180000	1.333	1.750	1.88	5.00	1.56	.81	2.38	1.63	4.00	3.73	5.93	3.13	3.50	3.87	1.60	2.88	1/4-20
210000	1.750	2.063	2.44	6.00	1.88	1.00	3.00	2.00	4.75	4.11	6.37	3.75	4.25	4.31	1.88	3.16	5/16-18
240000	1.750	2.375	2.75	6.88	2.44	1.19	3.13	2.38	5.63	4.11	6.87	4.88	4.06	4.81	1.88	3.57	3/8-16
260000	1.750	2.625	2.94	7.44	2.44	1.34	3.50	2.69	6.00	4.11	6.99	4.88	5.00	4.94	1.88	3.69	3/8-16
320000	2.063	3.250	3.25	8.63	3.13	1.38	3.88	2.75	7.50	4.48	8.18	6.25	5.44	5.91	2.75	4.55	1/2-13
380000	2.063	3.750	3.94	10.06	3.44	1.50	4.25	3.00	8.56	4.48	8.68	6.08	6.69	6.41	2.75	5.05	1/2-13

OUTPUT SHAFT

SIZE	M	N**	KEYWAY
130000	1.50	.6240	.19 X .09
180000	1.75	.7490	.19 X .09
210000	1.97	.8740	.19 X .09
240000	1.72	.9990	.25 X .13
260000	2.25	1.1240	.25 X .13
320000	2.44	1.2490	.25 X .13
380000	3.00	1.4990	.38 X .19

**Optional output shaft diameters available for units with 1.75 C.D. and above. Consult factory.

*MOTOR FLANGE DIMENSIONS

MOTOR FRAME	AJ	AK	BD	BE	BF	BORE	KEYWAY
C = 56C	5.88	4.50	6.50	.31	.422	.6260	.19 X .09
L = ^{143TC} / _{145TC}	5.88	4.50	6.50	.31	.422	.8760	.19 X .09

ASSEMBLIES

STYLE H*D

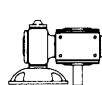

SUFFIX A

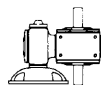

B

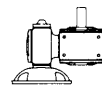

C

STYLE HA*D

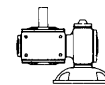

A

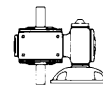

B

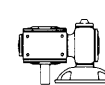

C

STYLE H*HD-HA*HD

MODULAR HOUSING
 QUILLED C-FACE INPUT
 HOLLOW OUTPUT SHAFT
 DOUBLE REDUCTION

DIMENSIONS

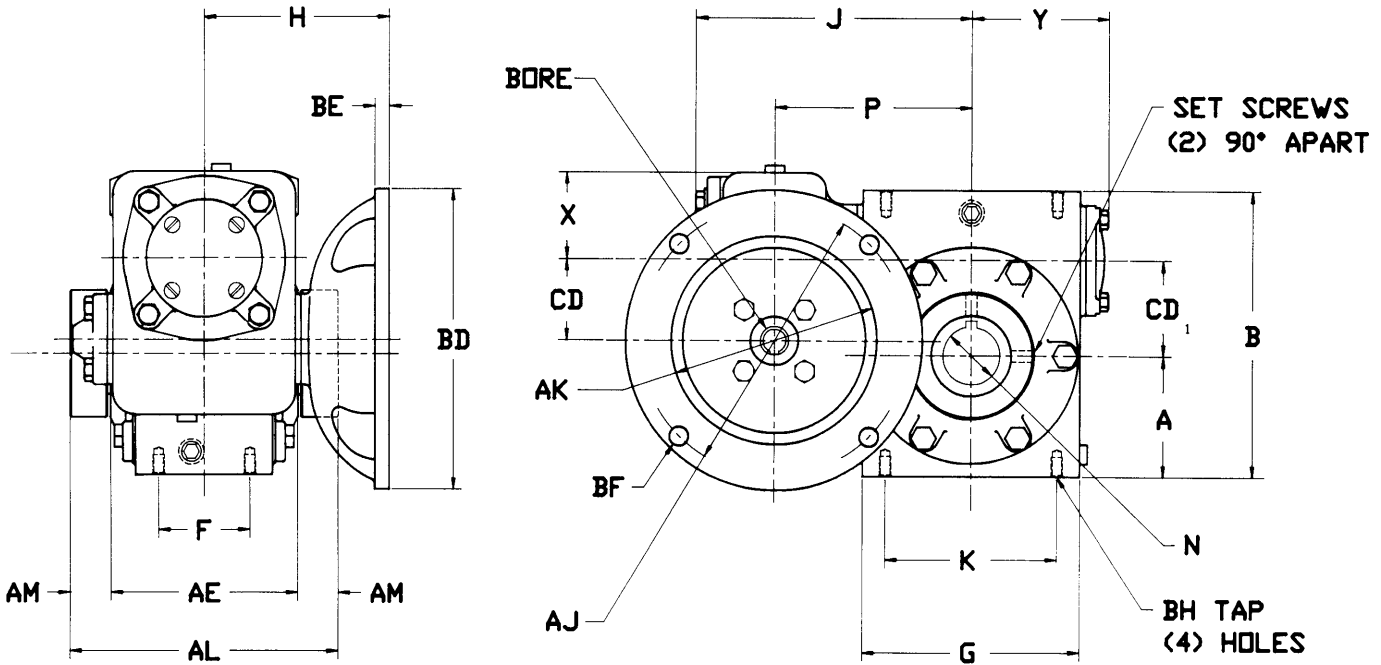

SIZE	CD	CD ₁	A	B	F	G	H	J	K	P	X	Y	AE	AL	AM	BH
180000	1.333	1.750	1.88	5.00	1.63	4.00	3.73	5.93	3.13	3.87	1.60	2.88	3.50	4.30	.65	1/4-20
210000	1.750	2.063	2.44	6.00	2.00	4.75	4.11	6.37	3.75	4.13	1.88	3.16	4.18	5.88	.85	5/16-18
240000	1.750	2.375	2.75	6.88	2.38	5.63	4.11	6.87	4.88	4.81	1.88	3.57	4.92	6.54	.81	3/8-16
260000	1.750	2.625	2.94	7.44	2.69	6.00	4.11	6.99	4.88	4.94	1.88	3.69	4.98	6.54	.78	3/8-16
320000	2.063	3.250	3.25	8.63	2.75	7.50	4.48	8.18	6.25	5.91	2.75	4.55	5.64	7.26	.81	1/2-13
380000	2.063	3.750	3.94	10.06	3.00	8.56	4.48	8.68	6.88	6.41	2.75	5.05	6.20	7.76	.78	1/2-13

*MOTOR FLANGE DIMENSIONS

MOTOR FRAME	AJ	AK	BD	BE	BF	BORE	KEYWAY
C = 56C	5.88	4.50	6.50	.31	.422	.6260	.19 X .09
L = 143TC 145TC	5.88	4.50	6.50	.31	.422	.8760	.19 X .09

HOLLOW BORE

SIZE	N**	KEY
180000	1.000	1/4 X 1/4
210000	1.250	1/4 X 1/4
240000	1.688	3/8 X 11/32
260000	1.688	3/8 X 11/32
320000	2.188	1/2 X 3/8
380000	2.438	1/2 X 3/8

ASSEMBLIES

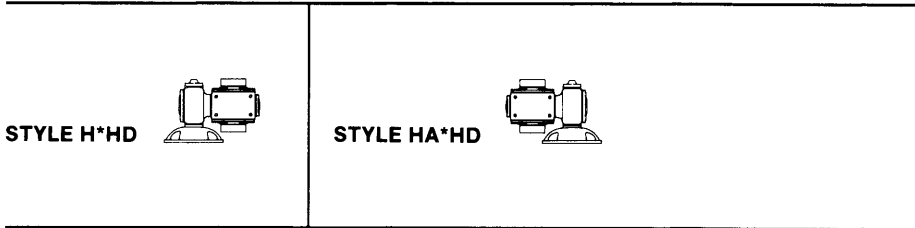

**Diameter is maximum. Bushings are available for smaller diameters. See page 62.

For ratings see page 14, 15 • For ordering information see page 44
 For base kits see page 59 • For torque arm kits see page 60
 Dimensions shown are for reference only • Certified prints available upon request • For mounting positions see page 68
 Service and maintenance see page 69

**SQUARE FLANGED
MODULAR HOUSING
QUILLED C-FACE INPUT
HOLLOW OUTPUT SHAFT
DOUBLE REDUCTION**

STYLE K*HD-KA*HD

DIMENSIONS

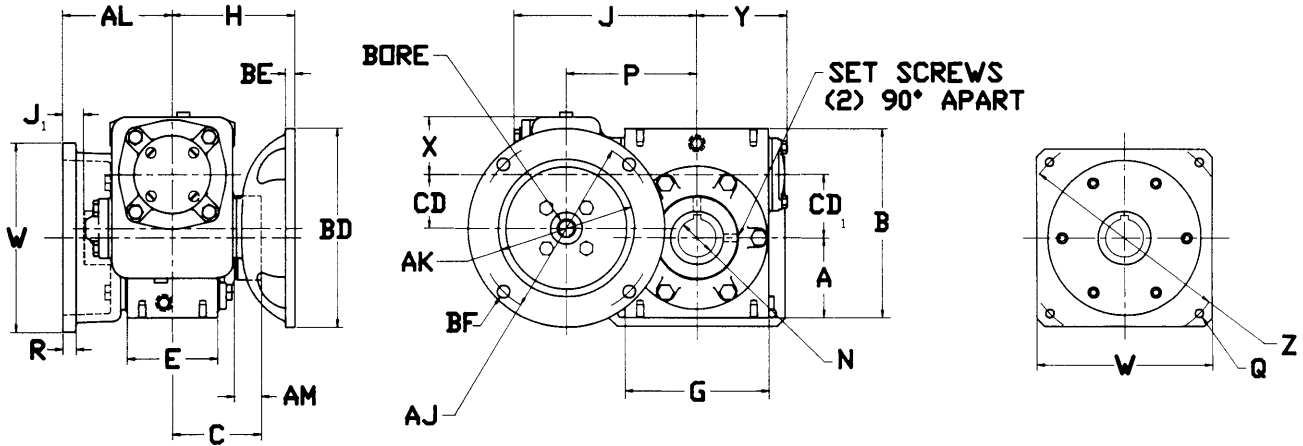

SIZE	CD	CD ₁	A	B	C	E	G	H	J	J ₁	P	Q	R	W	X	Y	Z	AL	AM
180000	1.333	1.750	1.88	5.00	2.40	2.38	4.00	3.73	5.93	.93	3.87	.34	.34	5.38	1.60	2.88	5.88	3.33	.65
210000	1.750	2.063	2.44	6.00	2.94	3.00	4.75	4.11	6.37	.71	4.31	.41	.44	5.81	1.88	3.16	7.00	3.65	.85
240000	1.750	2.375	2.75	6.88	3.27	3.13	5.63	4.11	6.87	.38	4.81	.41	.38	6.88	1.88	3.57	7.50	3.65	.81
260000	1.750	2.625	2.94	7.44	3.27	3.50	6.00	4.11	6.99	.38	4.94	.41	.38	6.88	1.88	3.69	8.00	3.65	.78
320000	2.063	3.250	3.25	8.63	3.63	3.88	7.50	4.48	8.18	.83	5.91	.56	.50	7.75	2.75	4.55	9.00	4.50	.81
380000	2.063	3.750	3.94	10.06	3.88	4.25	8.56	4.48	8.68	1.13	6.41	.56	.50	8.75	2.75	5.05	10.00	5.00	.78

HOLLOW BORE

SIZE	N**	KEY
180000	1.000	1/4 X 1/4
210000	1.250	1/4 X 1/4
240000	1.688	3/8 X 11/32
260000	1.688	3/8 X 11/32
320000	2.188	1/2 X 3/8
380000	2.438	1/2 X 3/8

*MOTOR FLANGE DIMENSIONS

MOTOR FRAME	AJ	AK	BD	BE	BF	BORE	KEYWAY
C = 56C	5.88	4.50	6.50	.31	.422	.6260	.19 X .09
L = ^{143TC} / _{145TC}	5.88	4.50	6.50	.31	.422	.8760	.19 X .09

ASSEMBLIES

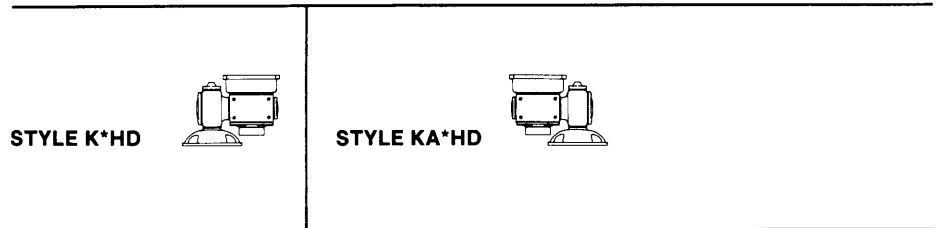

**Diameter is maximum. Bushings are available for smaller diameters. See page 62

STYLE K*D-KA*D

**SQUARE FLANGED
MODULAR HOUSING
QUILLED C-FACE INPUT
DOUBLE REDUCTION**

DIMENSIONS

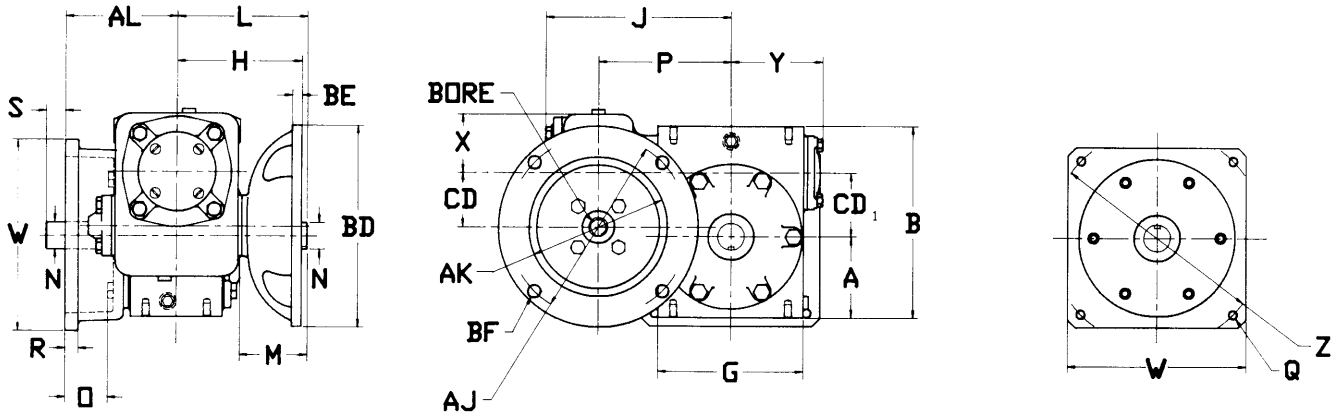

SIZE	CD	CD ₁	A	B	G	H	J	L	P	Q	R	S	W	X	Y	Z	AL
180000	1.333	1.750	1.88	5.00	4.00	3.73	5.93	3.50	3.87	.34	.34	.17	5.38	1.60	2.88	5.88	3.33
210000	1.750	2.063	2.44	6.00	4.75	4.11	6.37	4.25	4.31	.41	.44	.60	5.81	1.88	3.16	7.00	3.65
240000	1.750	2.375	2.75	6.88	5.63	4.11	6.87	4.06	4.81	.41	.38	.41	6.88	1.88	3.57	7.50	3.65
260000	1.750	2.625	2.94	7.44	6.00	4.11	6.99	5.00	4.94	.41	.38	1.35	6.88	1.88	3.69	8.00	3.65
320000	2.063	3.250	3.25	8.63	7.50	4.48	8.18	5.44	5.91	.56	.50	.94	7.75	2.75	4.55	9.00	4.50
380000	2.063	3.750	3.94	10.06	8.56	4.48	8.68	6.69	6.41	.56	.50	1.69	8.75	2.75	5.05	10.00	5.00

ASSEMBLIES

STYLE K*D

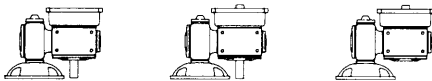

SUFFIX A

B

C

STYLE KA*D

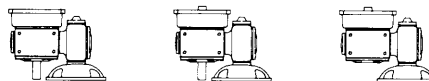

A

B

C

OUTPUT SHAFT

SIZE	M	N**	O	KEYWAY
180000	1.75	.8740	1.33	.19 X .09
210000	1.97	.9990	1.32	.25 X .13
240000	1.75	1.1240	1.13	.25 X .13
260000	2.25	1.2490	1.13	.25 X .13
320000	2.47	1.4990	1.37	.38 X .19
380000	3.00	1.6240	1.64	.38 X .19

**Optional Output Shaft diameters available, consult factory

*MOTOR FLANGE DIMENSIONS

MOTOR FRAME	AJ	AK	BD	BE	BF	BORE	KEYWAY
C = 56C	5.88	4.50	6.50	.31	.422	.6260	.19 X .09
L = ^{143TC} _{145TC}	5.88	4.50	6.50	.31	.422	.8760	.19 X .09

DIMENSIONS

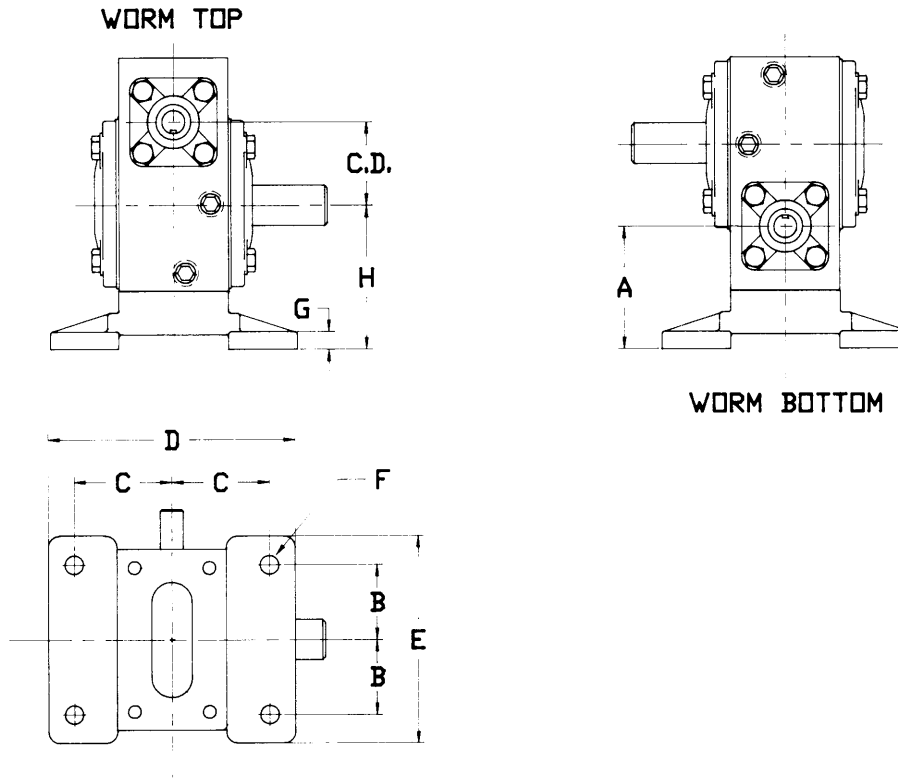

SERIES	STYLE	C.D.	A	B	C	D	E	F	G	H	KIT NUMBER
1300	WORM TOP	1.333	---	1.625	1.625	4.00	4.00	.28	.312	1.875	BA1302-01
1300	WORM BOTTOM	1.333	1.500	1.625	1.625	4.00	4.00	.28	.312	---	BA1302-01
1800	WORM TOP	1.750	---	2.000	1.750	4.50	5.00	.41	.375	2.250	BA1802-01
1800	WORM BOTTOM	1.750	1.750	2.000	1.750	4.50	5.00	.41	.375	---	BA1802-01
2100	WORM TOP	2.063	---	2.375	2.063	5.13	5.75	.41	.375	3.125	BA2102-02
2100	WORM BOTTOM	2.063	2.000	2.375	2.063	5.13	5.75	.41	.500	---	BA2102-01
2400	WORM TOP	2.375	---	2.750	2.063	5.13	6.50	.41	.500	3.500	BA2402-01
2400	WORM BOTTOM	2.375	2.250	2.750	2.063	5.13	6.50	.41	.500	---	BA2402-02
2600	WORM TOP	2.625	---	2.938	2.375	5.75	7.00	.47	.688	3.625	BA2602-01
2600	WORM BOTTOM	2.625	2.500	2.938	2.375	5.75	7.00	.47	.625	---	BA2602-02
3200*	WORM TOP	3.250	---	4.750	3.063	7.50	10.75	.53	.750	4.375	BA3202-05
3200*	WORM BOTTOM	3.250	3.500	4.750	3.063	7.50	10.75	.53	.750	---	BA3202-06
3800*	WORM TOP	3.750	---	5.187	3.500	8.50	12.00	.59	.750	4.813	BA3802-05
3800*	WORM BOTTOM	3.750	3.750	5.187	3.500	8.50	12.00	.59	.750	---	BA3802-06

For base kits to match your requirements, consult factory.
*These bases do not match standard Perfection reducers.

ACCESSORIES

TORQUE ARM KITS

DIMENSIONS

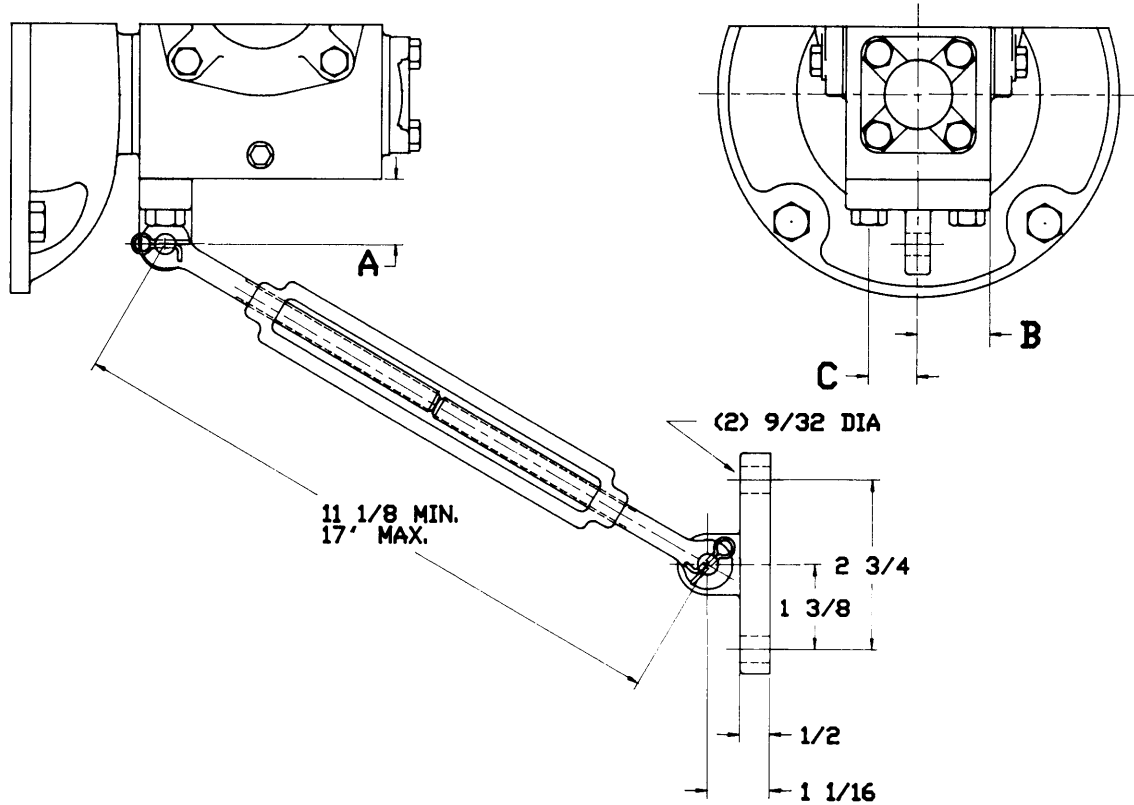

SERIES	A	B	C	P.NO.
1800	1.06	1.25	.81	TB1823
2100	1.06	1.50	1.00	TB2123
2400	1.06	1.56	1.19	TB2423
2600	1.06	1.75	1.34	TB2623
3200	1.06	1.94	1.38	TB3223
3800	1.06	2.13	1.50	TB3823

Torque arm kits include two brackets, turnbuckle, and bolts.

Used with hollow shaft reducers for shaft mounting • To order use part number shown
 Dimensions shown are for reference only • Certified prints available upon request

DIMENSIONS

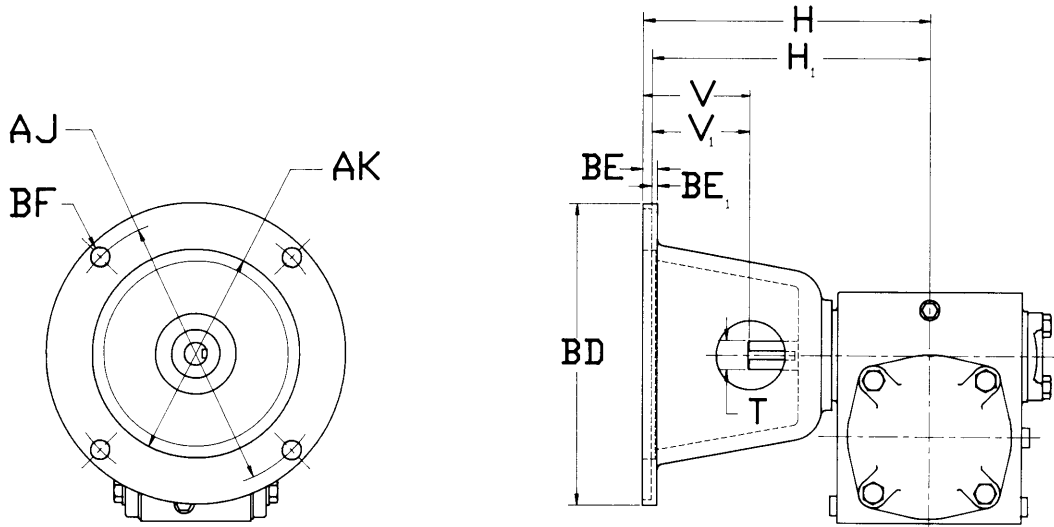

SERIES	MO. FR.	AJ	AK	BD	BE	BE ₁	BF	H	H ₁	T	V	V ₁	P. NO.
1300	56C/140TC	5.88	4.50	6.50	.406	---	.406	5.91	---	.4995	2.41	---	M1356
1800	56C/140TC	5.88	4.50	6.50	.406	---	.406	6.29	---	.4995	2.29	---	M1356
2100	56C/140TC	5.88	4.50	6.50	.406	---	.406	6.60	---	.6245	2.29	---	M2156
2400	56C/140TC	5.88	4.50	6.50	.406	---	.406	7.79	---	.7495	2.53	---	M2456
2600	56C/140TC	5.88	4.50	6.50	.406	---	.406	7.91	---	.7495	2.28	---	M2456
2400	180TC	7.25	8.50	9.00	---	.281	.531	---	7.50	.7495	---	2.90	*
2600	180TC	7.25	8.50	9.00	---	.281	.531	---	7.63	.7495	---	2.93	*

*Available on units from factory only.
Motor adapter kit includes oil seals and bolts.

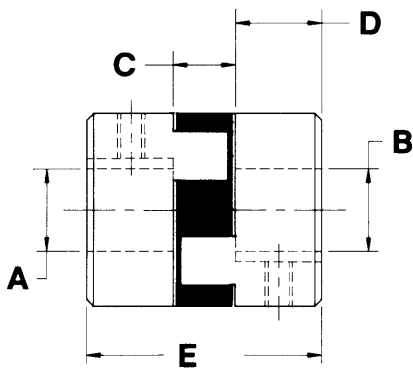

Part Number	Reducer Shaft (A)	Motor Shaft (B)	C	D	E
CP1856	.4995	.6245	.50	.81	2.13
CP2156	.6245	.6245	.50	.81	2.13
CP21140	.6245	.8745	.50	.81	2.13
CP2456	.7495	.6245	.50	.81	2.13
CP24140	.7495	.8745	.50	.81	2.13
CP24180	.7495	1.125	.50	1.00	2.50

H.P. RATINGS

RPM	100	300	600	900	1200	1800	3600
H.P.	.60	1.80	3.60	5.40	7.20	10.8	21.60

ACCESSORIES

HOLLOW SHAFT OUTPUT BUSHINGS QUILLED C-FACE INPUT BUSHINGS

HOLLOW SHAFT BUSHINGS

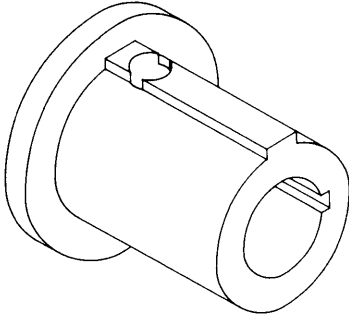

Use with hollow shaft reducers for shaft mounting

BORE SIZE	KEYWAY	1800 SERIES	2100 SERIES	2400 SERIES	2600 SERIES	3200 SERIES	3800 SERIES
.625	3/16 x 3/32	BU1810					
.688	3/16 x 3/32	BU1811					
.750	3/16 x 3/32	BU1812					
.875	3/16 x 3/32	BU1814	BU2114				
.938	1/4 x 1/8	(1)	BU2115				
1.000	1/4 x 1/8	STD	BU2116	BU2416	BU2416		
1.125	1/4 x 1/8		(1)	BU2418	BU2418		
1.188	1/4 x 1/8		(1)	BU2419	BU2419		
1.250	1/4 x 1/8		STD	BU2420	BU2420	BU3220	
1.375	5/16 x 5/32			BU2422	BU2422	BU3222	
1.438	3/8 x 3/16			BU2423	BU2423	BU3223	
1.500	3/8 x 3/16			BU2424	BU2424	BU3224	BU3824
1.625	3/8 x 5/32			(1)	(1)	BU3226	BU3826
1.688	3/8 x 5/32			STD	STD	BU3227	BU3827
1.750	3/8 x 3/16					BU3228	BU3828
1.875	1/2 x 1/4					BU3230	BU3830
1.938	1/2 x 1/4					BU3231	BU3831
2.000	1/2 x 1/4					BU3232	BU3832
2.125	1/2 x 1/8					(1)	BU3834
2.188	1/2 x 1/8					STD	BU3835
2.250	1/2 x 1/4						BU3836
2.375	1/2 x 1/8						(1)
2.438	1/2 x 1/8						STD

(1) Available from factory as alternate shaft only

QUILLED C-FACE INPUT BUSHINGS

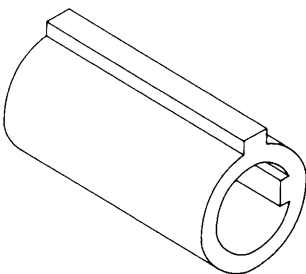

REDUCTION FROM TO	O.D. BORE	O.D. KEYSIZE	I.D. BORE	I.D. KEYSIZE	PART NUMBER
180TC / 140TC	1.125	1/4 x 1/8	.875	3/16 x 3/32	TM3293B
140TC / 56C	.875	3/16 x 3/32	.625	3/16 x 3/32	TM3293
56C / 48C	.625	3/16 x 3/32	.500	FLAT	TM3293A

Use with quilled C-face input reducers to change motor shaft sizes without changing worms.

SPIRAL BEVEL GEAR BOXES

USES AND ADVANTAGES

Bevel Gear Boxes transfer power at 90°, the most popular being a 1:1 ratio with relation to speed. These units are capable of reducing ratios up to 6:1, depending on physical dimensions. During recent years these units have been used as speed increasers by driving the unit in reverse (using normal output as the input). Bevel Gear Boxes are selected for speed, ratio, horsepower and torque.

The Perfection Spiral Bevel Gear Boxes design features the long life required for use with industrial equipment. All units offer universal mounting, spring loaded seals and Gleason tooth form. Units can be shipped with lubricant and feature tapered roller bearing construction on alloy steel shafts. All gear boxes are interchangeable with all major makes and cover a power range of 1/3 to 45 horsepower.

PRECISION ENGINEERED AND PERFORMANCE TESTED

Perfection Gear Spiral Bevel Gear Boxes are **precision** units throughout. A precision set of Spiral Bevel Gears are produced and assembled as sets. Then are precisely and rigidly mounted on antifriction bearings, and contained in a tight cast iron housing that allows continuous lubrication and an adequate heat dissipation. Clean, simple, and precise.

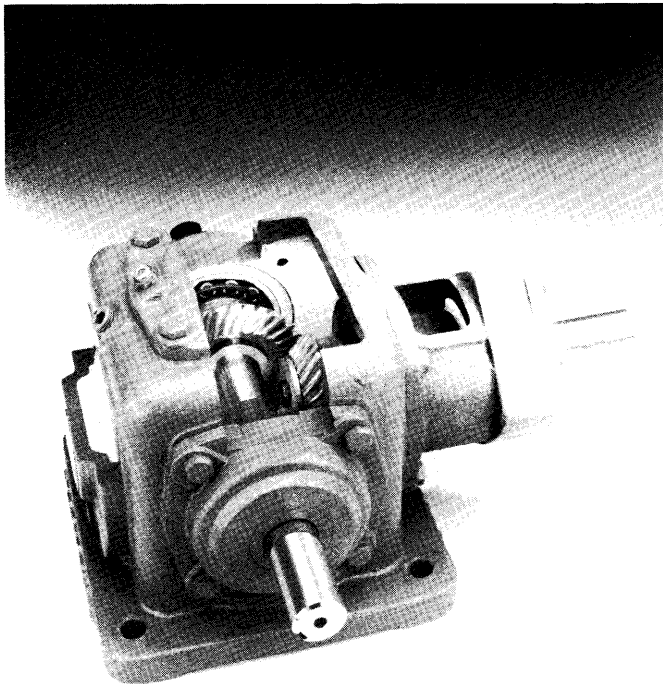

SPIRAL BEVEL GEAR BOX COMPONENTS

There are six main components that make up the Spiral Bevel Gear Box — gear set, shaft, housing, caps, bearings and seals.

THE GEAR SET: Perfection Gear uses only Spiral Bevel Gears. They are made from 8620 Alloy Steel and then case hardened to 57-62 Rockwell for wearability, retaining a tough ductile core for maximum strength.

THE SHAFTS: All are made from Stressproof¹ Steel which is a treated, stress-relieved medium-carbon steel. The structure of this material permits it to carry full torsional and overhung load. The shaft is ground, and the area in contact with the oil seal is polished.

HOUSINGS: All housings are one-piece castings, made from close grained, gray iron. The use of cast iron gives the rigidity, strength and dimensional stability that the gearing and bearings need for long dependable service. Precision CNC machining in one setup insures the accuracy needed for proper mounting of the Spiral Bevel Gears.

CAPS: All caps are bolt on caps made of cast grey iron material. This allows for fine adjustment of the gearing, bearing preload by the use of shims, and ease of maintenance. This also adds to the dimensional stability of the reducer.

BEARINGS: All bearings are Tapered Roller Bearings.

SEALS: Every unit is tested thoroughly to insure that all oil seals function properly by applying air pressure to the gear box while submerged in a water tank. This method allows the detection of even the smallest leaks and is used on 100% of all Perfection Reducers. Seal material on standard units are nitrile, good for temperatures from -65° to 225° F. Other seal materials are available to meet extreme conditions.

¹ Stressproof is a registered trademark of the LaSalle Steel Co.

SPIRAL BEVEL GEAR BOX ENGINEERING DATA AND RATINGS

RATINGS (1.0 SERVICE FACTOR)

RATIO	INPUT RPM	O.P. RPM	SIZE 4000		SIZE 6000		SIZE 8000	
			INPUT H.P.	OUTPUT TORQUE	INPUT H.P.	OUTPUT TORQUE	INPUT H.P.	OUTPUT TORQUE
1:1	1750	1750	8.0	288	20.0	720	45.0	1620
	1150	1150	5.4	296	13.6	745	31.0	1700
	850	850	4.0	298	10.4	770	23.5	1740
	690	690	3.3	301	8.6	785	20.0	1825
	100	100	.60	378	1.6	1010	4.0	2520
1.5:1	1750	1166	5.8	311	16.0	865	32.5	1750
	1150	767	3.8	312	10.5	865	21.5	1770
	850	467	2.8	313	7.8	868	16.0	1786
	690	460	2.3	315	6.4	876	13.0	1795
	100	67	.36	340	.97	916	2.6	2460
2:1	1750	875	3.4	245	11.2	808	21.0	1515
	1150	575	2.3	252	7.5	822	13.9	1525
	850	425	1.7	253	5.6	830	10.4	1540
	690	345	1.4	256	4.7	858	8.5	1555
	100	50	.21	265	.73	920	1.4	1760
OVERHUNG LOAD			350		665		1690	
NET WEIGHT			23.5		42		87	
OIL CAPACITY			14		32		64	

CLASSES OF SERVICE

A 1.00 Service Factor is used when the application is free from recurrent Shock Loading and is continuous but does not exceed 10 hours per day. Using the Service Factor Table, select the proper Overload

Service Factor for your application and apply this formula:

$$\frac{\text{HP (from above)}}{\text{SERVICE FACTOR (from below)}} = \text{application HP}$$

SERVICE FACTORS FOR SPIRAL BEVEL GEAR BOXES

PRIME MOVER	DURATION OF SERVICE	DRIVEN MACHINE LOAD CLASSIFICATION		
		UNIFORM	MODERATE SHOCK	HEAVY SHOCK
ELECTRIC MOTOR	OCCASIONAL 1/2 HOUR PER DAY	0.50	0.80	1.25
	INTERMITTENT 3 HOURS PER DAY	0.80	1.00	1.50
	UP TO 10 HOURS PER DAY	1.00	1.25	1.75
	24 HOURS PER DAY	1.25	1.50	2.00
MULTI-CYLINDER INTERNAL COMBUSTION ENGINE	OCCASIONAL 1/2 HOUR PER DAY	0.80	1.00	1.50
	INTERMITTENT 3 HOURS PER DAY	1.00	1.25	1.75
	UP TO 10 HOURS PER DAY	1.25	1.50	2.00
	24 HOURS PER DAY	1.50	1.75	2.25
SINGLE CYLINDER INTERNAL COMBUSTION ENGINE	OCCASIONAL 1/2 HOUR PER DAY	1.00	1.25	1.75
	INTERMITTENT 3 HOURS PER DAY	1.25	1.50	2.00
	UP TO 10 HOURS PER DAY	1.50	1.75	2.25
	24 HOURS PER DAY	1.75	2.00	2.50

HOW TO ORDER SPIRAL BEVEL GEAR BOXES

When ordering PLEASE use the model number. The examples below may be used to form a model number when the size, ratio and assembly have been determined.

RH	G	4	151	R	C
Style	Relative Rotation	Size	Ratio	Mounting Position	Shaft Projection

MOUNTING STYLE:

RH - Input Horizontal
 RB - Input Vertical Down
 RT - Input Vertical Up

RELATIVE ROTATION:

Leave out if standard
 G - If Opposite

SIZE:

4 - 4000 Series
 6 - 6000 Series
 8 - 8000 Series

RATIO:

1.0:1 = 101
 1.5:1 = 151
 2.0:1 = 201

MOUNTING POSITION: See Page 67

Leave Out if Floor Mount
 L - Left Wall Mount
 R - Right Wall Mount
 C - Ceiling Mount

SHAFT PROJECTION: (When Facing Input)

A - Right Side
 B - Right and Left Sides
 C - Left Side
 D - Top Side
 E - Top and Bottom Sides
 F - Bottom Side

MODEL NUMBER EXAMPLES:

RHG 4151 RA

RB 4201 LC

SPIRAL BEVEL GEAR BOXES

DIMENSIONS

STYLE RH

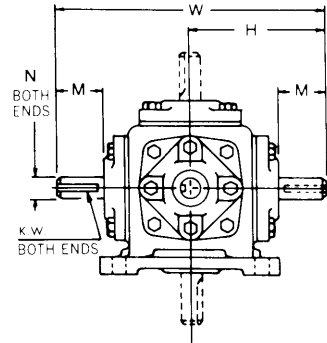
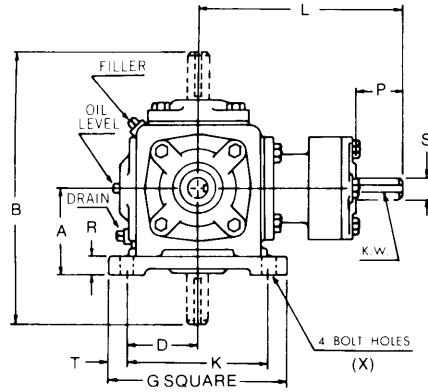

STYLE RB

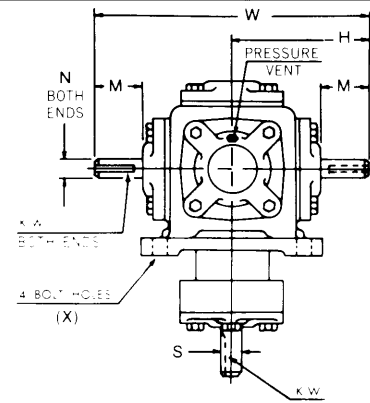
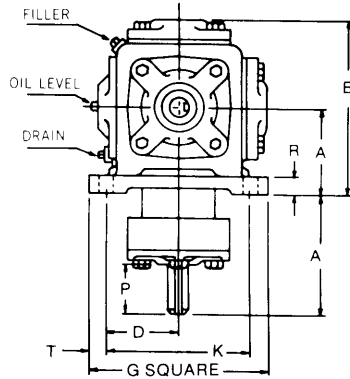

STYLE RT

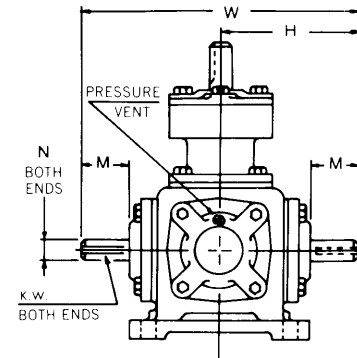
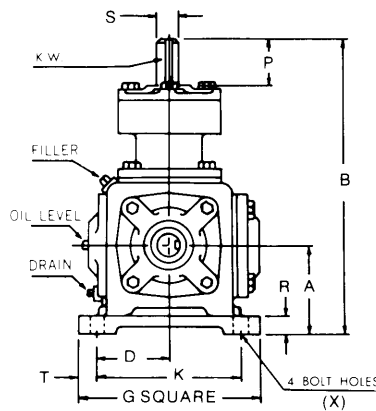

STYLE	A	A ₁	B			D	G	H	K	L	M	OUTPUT SHAFT * N KEYWAY		P	R	OUTPUT SHAFT * S KEYWAY		T	W	X
			ALL	RB	RH							RT	ALL			ALL	ALL			
SIZE																				
R-4101-B																				
R-4151-B	3.00	4.06	9.13	5.94	10.06	2.44	6.13	4.56	4.88	7.06	1.63	.7495	.188x.094	1.63	.69	.7495	.188x.094	.63	9.13	.44
R-4201-B																				
R-6101-B																				
R-6151-B	3.50	5.25	12.38	7.09	12.25	3.00	7.38	6.19	6.00	8.75	2.13	.9995	.250x.125	2.13	.75	.9995	.25x.125	.69	12.38	.56
R-6201-B																				
R-8101-B																				
R-8151-B	4.50	7.38	15.88	8.81	16.38	3.75	9.00	7.94	7.50	11.88	3.13	1.4995	.375x.188	3.13	.88	1.4995	.375x.188	.75	15.88	.56
R-8201-B																				

*Input Shaft reference is made only to Bevel Gear Boxes. Miter Gear Boxes can be driven from any shaft.

SPIRAL BEVEL GEAR BOXES

RH HORIZONTAL STYLE

Shafts can rotate in both directions. Relative rotations shown are standard for RH style. For opposite relative rotation specify RHG style.

Assembled To Order from STOCK Components At No Extra Charge

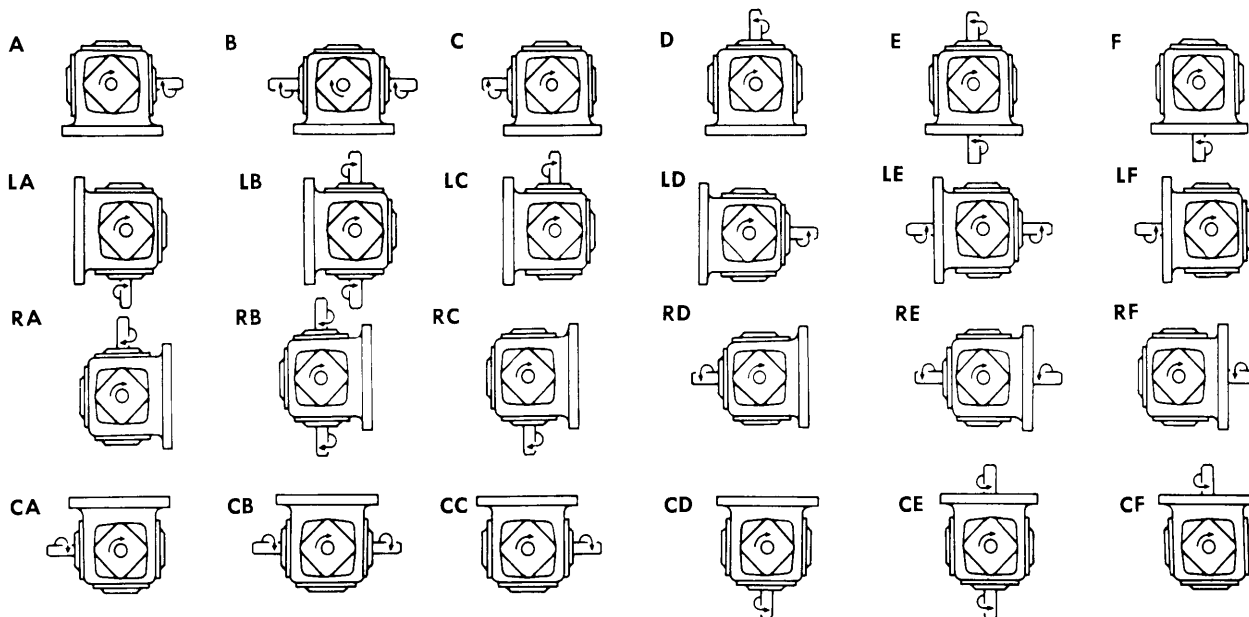

RB VERTICAL BOTTOM STYLE

Shafts can rotate in both directions. Relative rotations shown are standard for RB style. For opposite relative rotation specify RBG style.

Assembled To Order from STOCK Components At No Extra Charge

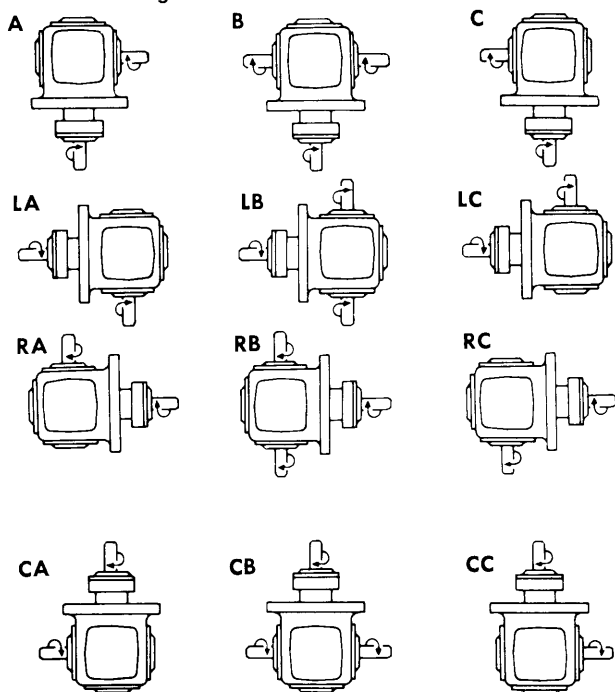

RT VERTICAL TOP STYLE

Shafts can rotate in both directions. Relative rotations shown are standard for RT style. For opposite relative rotation specify RTG style.

Assembled To Order from STOCK Components At No Extra Charge

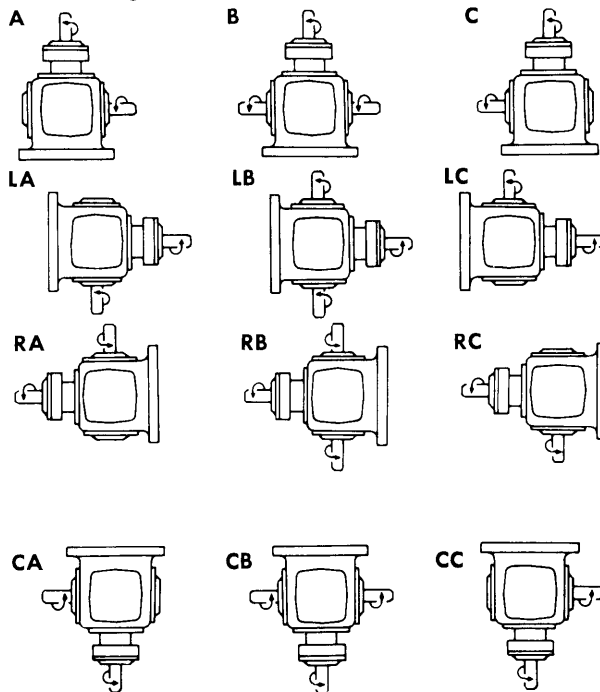

OIL LEVEL PLUG LOCATION

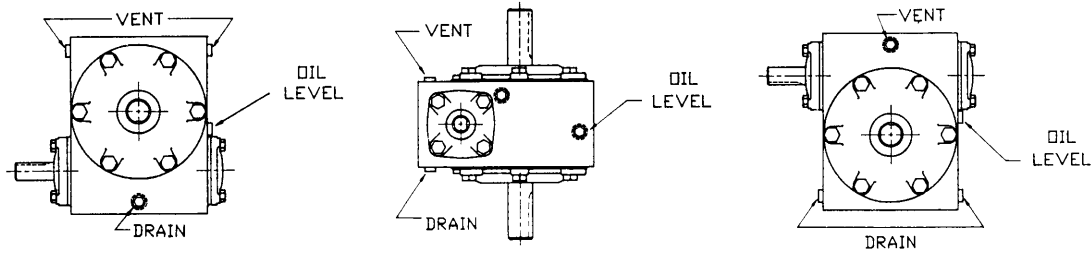

Before installing your Perfection Gear reducer check the oil level and install the pressure vent (supplied) in the position indicated above. On double reduction

units both the primary and the secondary reducers must be lubricated and vents installed.

APPROXIMATE OIL CAPACITIES BY STYLE IN OUNCE

SIZE	SB SBF	ST STF T* T°F	ALL— H, V R, N, K	SD SCD	TD		HD, H*D, K*D, VD, V*D RD, R*D, ND, N*D		T*D, MT*D	
					PRIMARY	SECONDARY	PRIMARY	SECONDARY	PRIMARY	SECONDARY
1300	2	3	5							
1800	4	5	9							
2100	7	10	18							
2400	10	15	21							
2600	13	17	30							
3200	22	26	48							
3800	32	45	64							
4500	48	56	105							
5200	64	80	128							
130000				10	1.75	3	2.25	5	2.25	3
180000					1.75	5	2.25	9	2.25	5
210000					3.5	10	3.5	18	3.5	10
240000					3.5	15	3.5	21	3.5	15
260000					3.5	17	3.5	30	3.5	17
320000					6.5	26	8.5	48	6.5	26
380000					6.5	45	8.5	64	6.5	45
450000					12.5	56	16	105	12.5	56
520000					12.5	80	16	128	12.5	80

AVERAGE WEIGHTS BY STYLE IN LBS.

STYLE SIZE	SB	ST	H	V	R, N	K	SD	TC, TL	HC, HL	VC, VL	RC, RL	KC, KL	SCD
1300	9.5	9.5	9.5	11.5	12.5	---	---	14.2	14.2	16.2	17.2	---	---
1800	13.5	13.5	13.5	16.5	18.5	22.5	---	19.5	19.5	22.5	24.5	28.5	---
2100	22.0	22.0	22.0	26.0	28.0	32.5	---	28.0	28.0	32.0	34.0	38.5	---
2400	29.0	29.0	29.0	34.0	37.0	41.0	---	35.0	35.0	40.0	43.0	47.0	---
2600	33.0	33.0	33.0	39.0	43.0	47.0	---	39.0	39.0	45.0	49.0	53.0	---
3200	51.0	51.0	51.0	61.0	66.0	70.0	---	57.0	57.0	67.0	72.0	76.0	---
3800	73.0	73.0	73.0	85.0	90.0	95.0	---	79.0	79.0	91.0	96.0	101	---
4500	102	102	---	120	125	---	---	108	---	126	131	---	---
5200	131	131	---	160	165	---	---	137	---	166	171	---	---
130000	---	17.0	17.0	19.5	20.5	---	16.0	23.0	23.0	25.5	25.2	---	20.7
180000	---	21.0	21.0	24.0	26.0	29.0	---	27.0	27.0	30.0	32.0	35.0	---
210000	---	33.0	33.0	37.0	39.0	42.0	---	39.0	39.0	43.0	45.0	48.0	---
240000	---	41.0	41.0	46.0	48.5	52.5	---	47.0	47.0	52.0	54.5	58.5	---
260000	---	46.5	46.5	52.5	56.5	60.5	---	52.5	52.5	58.5	62.5	66.5	---
320000	---	67.5	67.5	77.5	82.5	86.5	---	73.5	73.5	83.5	88.5	92.5	---
380000	---	90.0	90.0	102	108	113	---	96.0	96.0	108	114	119	---
450000	---	130	---	148	155	---	---	136	---	154	161	---	---
520000	---	160	---	189	194	---	---	166	---	195	200	---	---

SERVICE INFORMATION

For normal operating conditions where surrounding temperatures are within the limits of 50°F to 120°F we recommend the use of AGMA Lubricant #8 COMP, 8EP or similar oil of equal viscosity and composition. Below 50°F this oil should be AGMA Lubricant #7 COMP, 7EP.

The maximum efficiency of Worm Gear Reducers is obtained after a "Run-In" period. The length of time required will depend on the load applied. At full rated load the "Run-In" period will take approximately 24 hours and considerably longer at lighter loads. Overloading the unit WILL NOT decrease the "Run-In" period and may cause damage to internal components. During the "Run-In" period, higher than normal current, higher than normal temperature rise and lower efficiency and output torque can be expected.

Fill units only up to oil level and maintain this level. After the first 500 hours or 4 weeks of operation, and after each succeeding 2500 hours of operation or every 6 months thereafter (which ever occurs first) drain the oil, flush out the case and refill to proper level using the recommended oil or equivalent.

CAUTION:

Both Primary and Secondary Reducers have individual oil reservoirs. Each Unit must be filled to and maintained at its individual oil level. See below for listing of Typical Manufacturer's Worm and Worm Gear Reducer oils meeting AGMA Standards. 250.04. Sept. 1981.

IMPORTANT:

ALL UNITS ARE SHIPPED WITH OIL UNLESS OTHERWISE SPECIFIED:

MANUFACTURER	90 WT.	FOR OPERATIONS IN 15°F to 50°F AMBIENT	140 WT.	FOR OPERATIONS IN 50°F to 120°F AMBIENT
Chevron Oil		NL Gear Guard COMP 220		NL Gear COMP 620
Exxon Petroleum		Spartan EP 220		Spartan EP 680
Mobil Oil Company		Mobilgear 630		Mobilgear 636
Shell Oil Company		Omala 71		Omala 81
Texaco Oil Company		Meropa 220		Meropa 680
Phillips Petroleum		All purpose gear oil SAE 90		All purpose gear oil SAE 140

LUBRICATION OF MITER AND BEVEL GEARBOXES

For normal operating temperatures within the limits of 40°F to 120°F we recommend multipurpose gear oil, SAE90W. Temperatures below 40°F, use 80W or contact factory.

APPROVED LUBRICANTS

Texaco	Multigear EP90
American	Multipurpose Gear Lubricant
Gulf	Transgear EP
Exxon	Gear Oil GP
Shell	Spirax EP
Mobil	Mobilube EP
Chevron	RPM Multiservice
Phillips	Philube All Purpose Gear Oil
CONACO	Polar Start 600 GM (For amb. temp. below 15°F.)

Or any Oil that meets MIL-L-2105B and GL5 specifications.

Additional products available from Perfection

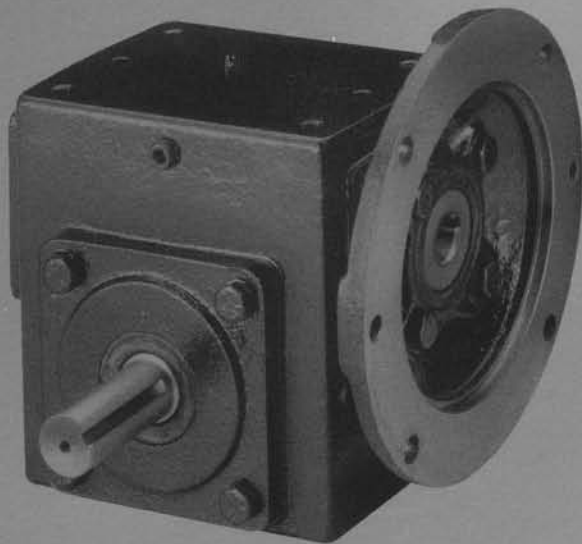

Predator[®] Reducers • 3.75 Center Distance • 1/8 through 9 H.P.

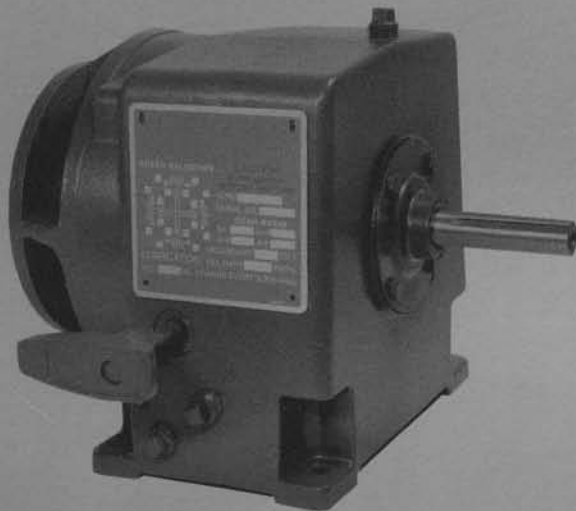

Transmissions • 4 Speed • 3/4 through 25 H.P.

PEERLESS-WINSMITH, INC.
**MOTORS
and GEARING**



PERFECTION GEAR, INC.
SUBSIDIARY OF PEERLESS-WINSMITH, INC.

9 NORTH BEAR CREEK RD., ASHEVILLE, NC 28806-1731
800/532-5314 • FAX 828/253-2649